



OWNER'S MANUAL

REFRIGERATOR

Read this owner's manual thoroughly before operating the appliance and keep it handy for reference at all times.



MFL69124626
Rev.00_061616

www.lg.com

TABLE OF CONTENTS

This manual may contain images or content different from the model you purchased.
This manual is subject to revision by the manufacturer.

SAFETY INSTRUCTIONS	03
INSTALLATION.....	11
Compartments	11
Notes for Moving and Transporting	12
Notes for Installation.....	12
Removing the Door.....	12
Refitting the Door.....	14
Adjusting the Height of the Door.....	14
Connecting the Water Line (For Plumbed models Only)	15
OPERATION	18
Parts and Functions.....	18
Notes for Operation	22
Control Panel.....	23
Water Dispenser Tank (Non plumbed models only)	25
Water and Ice Dispenser	26
Automatic Icemaker.....	26
Door in Door (Optional)	28
Fresh Vegetable Drawer (Optional).....	29
Other Functions	29
SMART FUNCTION	30
Application Installation.....	30
Product Registration	30
Using the Tag On Function	30
Using Smart Diagnosis™	31
MAINTENANCE	33
Notes for Cleaning	33
Replacing the Pure N Fresh Filter (Optional)	33
Cleaning the Door Basket.....	34
Cleaning the Shelf	34
Cleaning the Water Dispenser.....	35
Replacing the Water Filter (For Plumbed models Only)	35
TROUBLESHOOTING.....	36

SAFETY INSTRUCTIONS

The following safety guidelines are intended to prevent unforeseen risks or damage from unsafe or incorrect operation of the appliance.

The guidelines are separated into 'WARNING' and 'CAUTION' as described below.

 This symbol is displayed to indicate matters and operations that can cause risk. Read the part with this symbol carefully and follow the instructions in order to avoid risk.

 **WARNING**

To reduce the risk of explosion, fire, death, electric shock, injury or scalding to persons when using this product, follow basic precautions, including the following:

 **CAUTION**

This indicates that failure to follow the instructions can cause minor injury or damage to the product.

 **WARNING**

To reduce the risk of explosion, fire, death, electric shock, injury or scalding to persons when using this product, follow basic precautions, including the following:

Children in the Household

This appliance is not intended for use by persons (including children) with reduced physical, sensory or mental capabilities, or lack of experience and knowledge, unless they have been given supervision or instruction concerning use of the appliance by a person responsible for their safety. Children should be supervised to ensure that they do not play with the appliance.

Important Safety Instructions

Installation

- This appliance should only be transported by two or more people holding the appliance securely.
- Ensure that the outlet socket is properly grounded, and that the earth pin on the power cord is not damaged or removed from the power plug. For more details on grounding, inquire at an LG Electronics customer information centre.
- This appliance is equipped with a power cord having an equipment-grounding conductor and a grounding power plug. The power plug must be plugged into an appropriate outlet socket that is installed and grounded in accordance with all local codes and ordinances.
- If the power cord is damaged or the hole of the socket outlet is loose, do not use the power cord and contact an authorized service centre.
- Do not plug the appliance into a multi way power board, a double adaptor or an extension power cable.
- Do not modify or extend the power cord.
- Avoid using any extension cords or double adaptor. The appliance should be connected to a dedicated power line which is separately fused.
- Install the appliance in a place where is easy to unplug the power plug of the appliance.
- Be careful not to point the power plug up or let the appliance lean against the power plug.
- Install the appliance on a firm and level floor.
- Do not install the appliance in a damp and dusty place. Do not install or store the appliance in any outdoor area, or any area that is subject to weathering conditions such as direct sunlight, wind or rain or temperatures below freezing.

- Do not place the appliance in direct sunlight or expose it to the heat from heating appliances such as stoves or heaters.
- Be careful not to expose the rear of the appliance when installing.
- Be careful not to let the appliance door fall during assembly or disassembly.
- Be careful not to pinch, crush, or damage the power cable during assembly or disassembly of the appliance door.

Operation

- Do not use the appliance for any purpose (storage of medical or experimental materials or shipping) other than any domestic household food storage use.
- In case of flood, disconnect the power plug and contact the LG Electronics customer information centre.
- Unplug the power plug during a severe thunderstorm or lightening or when not in use for a long period of time.
- Do not touch the power plug or the appliance controls with wet hands.
- Do not bend the power cable excessively or place a heavy object on it.
- If water penetrates electrical parts of the appliance, disconnect power plug and contact an LG Electronics customer information centre.
- Do not place hands or metallic objects inside the area emitting the cold air, cover or heat releasing grille on the back.
- Do not apply excessive force or impact to the back cover of the appliance.
- Do not put animals, such as pets into the appliance.
- Be careful of nearby children when you open or close the appliance door. The door may bump the child and cause injury. Do not allow any persons to swing from any of the doors as it can cause the unit to topple over and cause serious injury.

- Avoid the danger of children getting trapped inside the appliance. A child trapped inside the appliance can cause suffocation.
- Do not place heavy or fragile objects, liquid filled containers, combustible substances, or flammable objects (such as candles and lamps) on the appliance.
- If there is a gas leakage (isobutane, propane, natural gas, etc.), do not touch the appliance or power plug and ventilate the area immediately. This appliance uses a very eco-friendly gas (isobutane, R600a) as the refrigerant. Although it uses a small amount of the gas, it is still combustible gas. Gas leakage during appliance transport, installation or operation can cause fire, explosion or injury if sparks are caused.
- Do not use or store flammable or combustible substances (ether, benzene, alcohol, chemical, LPG, combustible spray, insecticide, air freshener, cosmetics, etc.) near the appliance.
- Immediately unplug the power plug and contact an LG Electronics customer information centre if you detect a strange sound, odour, or smoke coming from the appliance.
- Fill with potable water only into icemaker or dispenser water tank.

Maintenance

- Disconnect the power cord before cleaning the appliance or replacing the inside lamp (where fitted).
- Securely plug the power plug in the outlet socket after completely removing any moisture and dust.
- Never unplug the appliance by pulling on the power cable. Always grip the power plug firmly and pull straight out from the socket outlet.
- Do not spray water inside or outside the appliance to clean it.

- Do not clean the appliance with brushes, cloths or sponges with rough surfaces or which are made of metallic material.
- Only a qualified service personnel from LG Electronics service centre should disassemble, repair, or modify the appliance. Contact an LG Electronics customer information centre if you move and install the appliance in a different location.
- Do not use a hair drier to dry the inside of the appliance or place a candle inside to remove the odours.

Disposal

- When discarding the appliance, remove the door gasket while leaving the shelves and baskets in place and keep children away from the appliance.
- Dispose of all packaging materials (such as plastic bags and styrofoam) away from children. The packaging materials can cause suffocation.

Technical safety

- Keep ventilation openings, in the appliance enclosure or in the built-in structure, clear of obstruction.
- Do not use electrical appliances inside the food storage compartments of the appliance, unless they are of the type recommended by the manufacturer.
- The refrigerant and insulation blowing gas used in the appliance require special disposal procedures. Consult with service agent or a similarly qualified person before disposing of them.
- This appliance contains a small amount of isobutane refrigerant (R600a), natural gas with high environmental compatibility, but it is also combustible. When transporting and installing the appliance, care should be taken to ensure that no parts of the refrigerating circuit are damaged.

- Refrigerant leaking out of the pipes could ignite or cause an explosion.
- If a leak is detected, avoid any naked flames or potential sources of ignition and air the room in which the appliance is standing for several minutes. In order to avoid the creation of a flammable gas air mixture if a leak in the refrigerating circuit occurs, the size of the room in which the appliance is used should correspond to the amount of refrigerant used. The room must be 1 m² in size for every 8 g of R600a refrigerant inside the appliance.
- The amount of refrigerant in your particular appliance is shown on the identification plate inside the appliance.
- Never start up an appliance showing any signs of damage. If in doubt, consult your dealer.
- Do not store explosive substances such as aerosol cans with a flammable propellant in this appliance.
- This appliance is intended to be used in household and similar applications only. It should not be used for commercial, or catering purposes, or in any mobile application such as a caravan or boat.



CAUTION

To reduce the risk of minor injury to persons, malfunction, or damage to the product or property when using this product, follow basic precautions, including the following:

Installation

- Do not tilt the appliance to pull or push it when transporting.

Operation

- Do not touch frozen food or the metal parts in the freezer compartment with wet or damp hands. It may cause frostbite.
- Do not place glass containers or bottles in the freezer compartment, shelves or ice bin that will be exposed to temperatures below freezing.
- The tempered glass on the front side of the appliance door or the shelves can be damaged by an impact. If it is broken, do not touch it with hands, as this may result in injury.
- Make sure your hands and feet do not get stuck when opening and closing the appliance door or the door in door.
- Do not place heavy objects on top of the door in door.
- Do not use the door in door as a chopping board and ensure it is not scratched by a sharp tool, as this may cause appliance damage.
- Do not store an excessive amount of water bottles or containers for side dishes on the door baskets. The basket may break or your hand may bump into the surrounding structure, causing injury.
- Keep food organized inside the appliance.
- Prevent animals from nibbling on the power cable or water hose.
- Do not open or close the appliance door with excessive force.
- If the hinge of the appliance door is damaged or operates improperly, stop using the appliance and contact an authorized service centre.
- Supervise a child or a person with poor cognitive skills to ensure they use the appliance safely. Do not damage the pipes of the refrigerant circuit.

- Do not place any electronic appliance (such as heater and mobile phone) inside the appliance.
- Do not clean glass shelves or covers with warm water when they are cold. They may break if exposed to sudden temperature changes.
- Never eat frozen foods immediately after they have been taken out in the freezer compartment
- Do not insert your hands into the mechanical part of the automatic icemaker such as the ice bin or the ice dispenser.
- Do not use a thin crystal cup or chinaware when using the dispenser.
- Do not remove the cover of the automatic icemaker. Touching any mechanical part of the automatic icemaker. It may result in injury.

Maintenance

- Do not insert the shelves upside down. The shelves may fall, causing injury.
- To remove frost from the appliance, contact an LG Electronics customer information centre.
- Dispose of the ice inside the ice bin in the freezer compartment during an extended power outage.
- Connect the water supply line (for plumbed models only) to a potable water source only. Otherwise, impurities in the water may cause illness.

INSTALLATION

Compartments

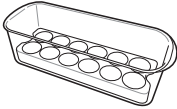
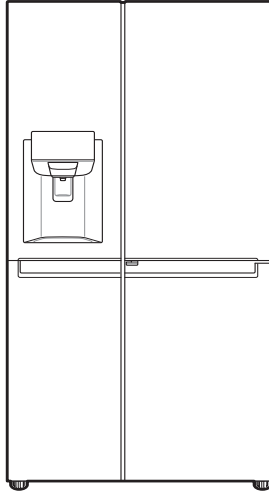

Egg Box (Optional)

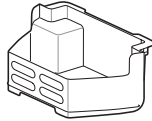

Freezer Basket



Owner's Manual

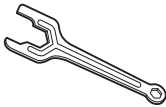

Spanner



Ring Sheet

- The appearance or components of the product may differ from model to model.

Notes for Moving and Transporting

- Remove all food from inside the appliance. Then, transport the appliance only after fixing fragile parts such as shelves and the door handle with tape. Failure to do so may cause appliance damage.
- Pull the power plug out, insert and fix it into the power plug hook at the rear or on top of the appliance. Failure to do so may cause damage to the power plug or floor scratch.
- When transporting the appliance, more than two people should transport the appliance carefully. Dropping the appliance, which is extremely heavy, may cause personal injury or appliance failure.
- When transporting the appliance over a long distance, keep the appliance upright. The appliance may fall over, causing malfunctions. Never transport the appliance laying down as it can cause a refrigerant circulation malfunction when it is turned back on again.

Notes for Installation

- Install the appliance on a solid and flat area.
 - If the appliance is installed on an uneven floor, it can cause vibration and noise causing the appliance to fall resulting in injury. It could also cause the doors not to close correctly and introduce moisture inside the unit during operation.
 - If the appliance front or rear is not level, adjust the front feet so that it can be corrected. Severe cases may need the floor to be packed out with strips of thin timber.
- Avoid placing the unit near heat sources, direct sunlight or moisture.
- Connect the power supply cord (or plug) to the outlet. Don't double up with other appliances on the same outlet.
- After connecting the power supply cord (or plug) to the outlet, Wait two or three hours before you put food into the appliance. If you add food before the appliance has cooled completely, your food may spoil.
- Models with handles should be located at least 55 mm from the wall on the hinge side to open door by 90°.
- Allow over 55 mm clearance to the right, left, back and top when installing.

Removing the Door

When it is necessary to move the appliance through a narrow opening, removing the doors is the recommended procedure.

WARNING

- Disconnect the power cord, house fuse or circuit breaker before installing or service the appliance. Failure to follow these instructions may result in death, fire or electric shock.

If your entrance door is too narrow for the appliance to pass through, remove the appliance doors and pass the appliance laterally.

[For freezer door only]

- 1 Hold the 2 tube connectors at the bottom of the appliance with your fingers and pull them out so that the hoses can then be carefully removed by following the instructions in step 2.

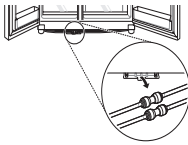

- 2 While pressing the collet part of the tube connector, remove the connected water tube.

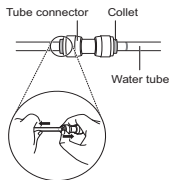

[For both freezer and fridge]

- 3 Remove the screw of the hinge cover on top of the appliance by rotating it counterclockwise.

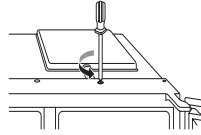

- 4 While pressing ① hook of the link of the electrical connectors, remove the link by pulling it in both directions.

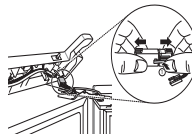

- 5 Remove the hinge lever by tapping the end of it toward the outside edge of the cabinet.

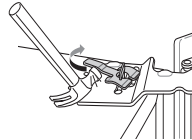

CAUTION

- When removing the upper hinge, be sure to support the door as it will fall forwards. It is recommended that 2 people carry out the door removal and refitting

- 6** Lift the upper hinge fixed between the appliance and the appliance door and then remove it.

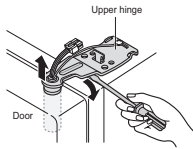

- 7** Remove the freezer and fridge compartment door by lifting it upward. At this time, the door should be lifted enough for the steel pipe to be completely pulled out.

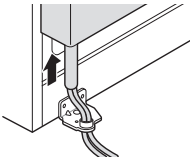

NOTE

- When moving the freezer door, be careful not to damage the water tubes. The doors should be laid down on a blanket in a safe area once they have been removed.
- If the water tube end is damaged, it should be trimmed to ensure it does not leak when refitted.



Refitting the Door

Mount them in the reverse sequence of removal after the appliance is passed through the access door.

Adjusting the Height of the Door

If the door of the appliance is not level, adjust the difference in the height of appliance door using the following method.

NOTE

- Because the hinge pin may fall out, do not adjust the height of the appliance door more than 5 cm.

[Method 1]

* Reference

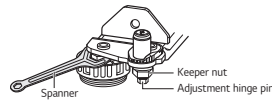

- 1** Loosen the keeper nut by rotating it counterclockwise using a 19 mm spanner.

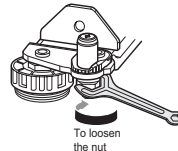

- 2** Adjust the difference in the height of the appliance door by rotating the adjustment hinge pin clockwise or counterclockwise with an 8 mm spanner.

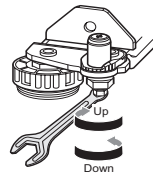

- 3** After adjusting the difference in the height of the appliance door, fasten the keeper nut by rotating it clockwise.

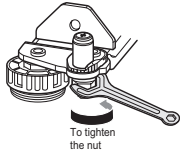

If it is impossible to adjust the height of the appliance door through the above method, level the door according to the following guide.

[Method 2]

- 1** When the appliance door is removed, loosen the screw at the bottom of the lower hinge.

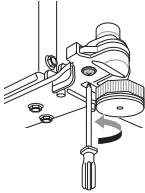

- 2** Insert the appropriate number of ring sheets between the lower hinge and the lower bracket. (Total number of ring sheets: 4)

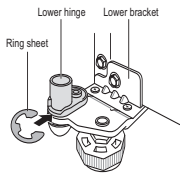

- 3** Resecure the bracket screw after fitting the ring sheets before refitting the door. When the door is refitted, steps 1,2 and 3 of adjusting the height of the door can then be repeated.

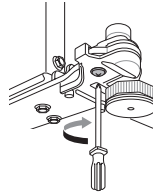

⚠ CAUTION

- When tilting the appliance backward to loosen the screen at the bottom of the appliance, more than two people should hold the handles at the bottom and rear top side of the appliance.

Connecting the Water Line (For Plumbed models Only)

Accessories



Water Filter (Optional)



Clip



Water Tube

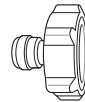

Tube Connector



Rubber Seal

Water Supply Requirements

A cold water supply with water pressure between 147 kPa and 834 kPa (1.5 - 8.5 kgf/cm²) is required to operate the water dispenser. If the refrigerator is installed in an area with low water pressure (below 147 kPa), you can install a booster pump to compensate for the low pressure.

If a reverse osmosis water filtration system is connected to your cold water supply, the water pressure to the reverse osmosis system needs to be a minimum of 147 kPa to 834 kPa (1.5 - 8.5 kgf/cm²)

WARNING

- Unplug the appliance before carrying out any work on connecting the water line. Failure to do so may cause electric shock.
- Only connect the water line to a cold water supply. Failure to do so may cause the water filter to malfunction. Water hammer (water banging in the pipes) within the house's plumbing can cause damage to appliance parts and can lead to water leakage or flooding.
- Connecting the water line must only be installed by a suitably qualified person. Not doing so could cause property damage due to an incorrect or poor connection.

NOTE

- This water line installation is not covered by the appliance warranty.

Connecting to the Appliance

- 1 Unscrew the metal threaded collar nut at the back of the appliance and place it over one end of the water tube.
- 2 Firmly push the water tube onto the water inlet valve and tighten up the collar nut.

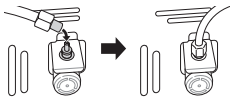

Connecting to the Water Filter

There are two types of filters. The methods of connection are different. One has a threaded plastic nut fitting and the other uses a self locking push fit connectors. The filter is marked with the direction of the water flow from the water tap to the appliance.

<Nut Type>

- 1 Unscrew the threaded connector and place it over the end of the cut section of pipe coming from the appliance. Push the pipe over the end of the filter that the flow arrow points to and tighten up the threaded connector.

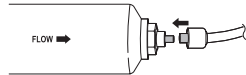

- 2 Repeat the same process on the other end of the filter using the remainder of the water tube.

<Push fit Connector Type>

- 1 Firmly push the water tube connected from the appliance into the end that has the arrow pointing outward. Push the tube all the way in (approx. 10 - 12 mm).

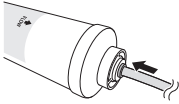

- 2 After inserting the tube securely into the filter, fit the locking clip into position under the pull up collar.

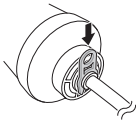

- 3 Repeat on the other end of the filter using the remainder of the water tube.

Connecting to the Water Tap

- 1 Push the water tube into the hole of the tap connector supplied in the accessories. The pipe should be held firmly whilst the connector is pushed onto the pipe.

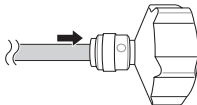

- 2 Ensure that the rubber washer is fitted to the inside of the tap connector before screwing it onto the correct type tap.

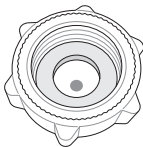

Checking the Water Connection

- 1 Turn on the water supply and switch on the appliance. Carefully check all fittings for possible leaks due to poorly fitted hoses.
- 2 Press and hold the Water Filter button for three seconds. This will reset the Replacement Filter icon. The new water filter has been activated.
- 3 Place a cup under the water dispenser to verify that water is flowing through the appliance. It is normal for cloudy water to be dispensed until the air from the filter is removed completely.
- 4 Check the connecting tube and joints for leaks once again.
- 5 The water filter should be located in an appropriate place where it is easy to reach for replacement purposes.

OPERATION

Parts and Functions

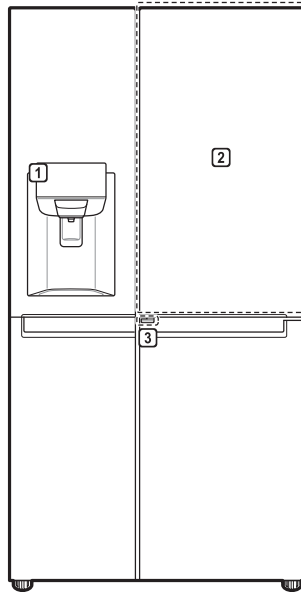

1 Control Panel

To set the freezer and fridge target temperatures.

2 Door in Door (Optional)

The Door inDoor is a double layered door system. It can be opened individually or together with the main door. You can conveniently locate and access your favourite snacks or food items.

3 Door in Door Lever (Optional)

This lever opens Door in Door.

- The appearance or components of the appliance may differ from model to model.

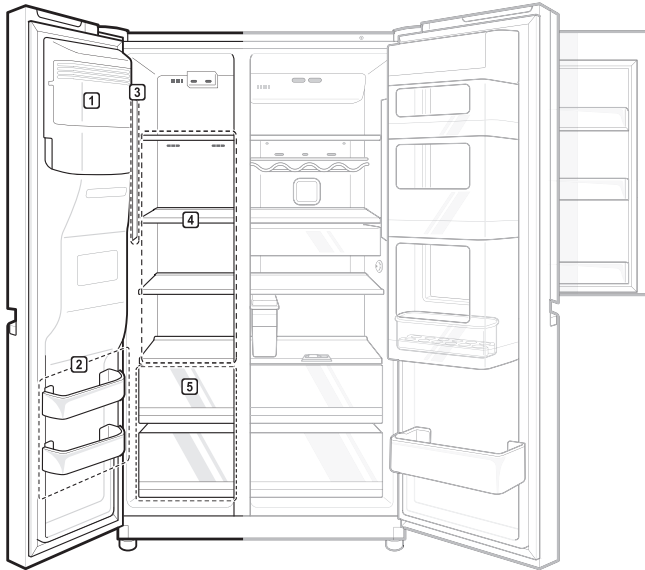

1 Automatic Icemaker

This is where ice is automatically produced and stored.

2 Freezer Door Basket

This is where small packages of frozen food can be stored.

- Do not store ice cream or food which will be stored for a long period of time within these baskets.

3 LED Lamp

The LED lamps inside the appliance light up when you open the door.

4 Freezer Shelf (Optional)

This is where frozen foods such as meat, fish, and ice cream, can be stored.

5 Freezer Drawer (Optional)

This is for long-term storage of frozen items.

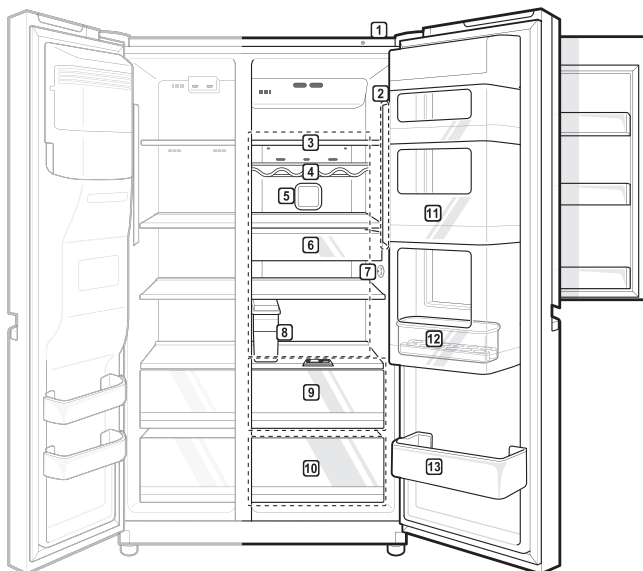

1 Smart Diagnosis Unit

Use this function when contacting LG Electronics customer information centre to help make an accurate diagnosis when the appliance operates abnormally or a failure occurs.

2 LED Lamp

The LED lamps inside the appliance light up when you open the door.

3 Fridge Shelf

This is where refrigerated foods and other items are stored.

- This adjusts the shelf height by inserting the shelf in another groove of different height.
- Store the foods with higher moisture content at the front of the shelf.
- The actual number of shelves will differ from model to model.

4 Bottle Rack (Optional)

This is where drinks tall bottles or containers are stored.

⚠ CAUTION

- Do not store short bottles or containers. The items may fall and to cause an injury or appliance damage.

5 Pure N Fresh (Optional)

This function minimizes bacteria and odor inside the appliance.

6 Snack Drawer (Optional)

This is where small packages of refrigerated foods are stored.

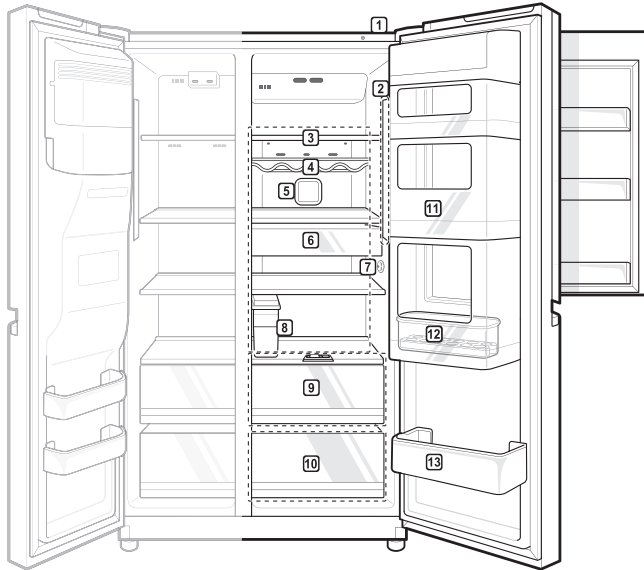

7 Temperature Sensor

This sensor senses the temperature of the fridge compartment.

- Maintain the distance between the sensor and food to accurately sense the temperature.

8 Water Dispenser Tank (Optional)

This is where water to supply the dispenser or the automatic icemaker is stored. It requires manual filling. (Non plumbed models only)

9 Fresh Vegetable Drawer (Optional)

This is where fruits and vegetables are stored to help maintain freshness by adjusting the humidity controller.

10 Vegetable Drawer

This is where fruits and vegetables are stored to remain fresh for as long as possible.

11 Door in Door (Optional)

This is where foods which are taken out frequently such as beverages and snacks are stored.

12 Movable Egg Box (Optional)

This is where eggs are stored.

- You can move it to and use it at a desired position as needed. However, do not use it as the ice bin or place it on the shelf on top of the fridge or the vegetable drawer.

13 Fridge Door Basket

This is where small packages of refrigerated foods, drinks and sauce containers are stored.

Notes for Operation

- Do not use the ice water dispenser tank for beverages other than drinking water.
- Users should keep in mind that frost can form if the door is not closed completely, if the humidity is high during the summer, or if the freezer door is opened frequently.
- Ensure there is sufficient space between food stored on the shelf or door basket to allow the door to close completely.
- Opening the door lets warm air enter the appliance, and may cause the internal temperature to rise.
- Do not open or close the appliance door excessively.
- The LED lamp is only intended for use in domestic appliances and is not suitable for household room illumination.

Suggestion for Energy Saving

- Ensure there is sufficient space between stored foods. This allows cold air to be circulated evenly and lowers electricity bills.
- Store hot food only after it has cooled in order to prevent dew or frost.
- When storing food in the freezer compartment, set the freezer temperature lower than the temperature indicated on the appliance.
- Do not set the temperature of the appliance lower than needed. For ice making in normal climates, the freezer temperatures should be set to -19 or colder.
- Do not put food near the temperature sensor of the fridge compartment. Keep a distance of at least 3 cm from the sensor.
- Please note that a temperature rise after defrosting has a permissible range in the appliance specifications. If you wish to minimise the impact this may have on the food storage due to a temperature rise, seal or wrap the stored food in several layers.

Storing Foods Effectively

- Store frozen food or refrigerated food inside sealed containers.
- Check the expiration date and label (storage instructions) before storing food in the appliance.
- Do not store food for a long period of time (more than four weeks) if it spoils easily at a low temperature.
- Place the refrigerated food or frozen food in each fridge or freezer compartment immediately after purchasing.
- Avoid refreezing any food which has been completely thawed. Freezing any food which has been completely thawed again will lower its taste and nutrition.
- Do not wrap and store vegetables with newspaper. Printing material of newspaper or other foreign substances may smear and contaminate food.
- Do not overfill the appliance. Fill less than 70 % of the space. Cold air can not circulate properly if the appliance is overfilled.
- Cool hot food before storing. If too much hot food is placed inside, the internal temperature of the appliance can increase and negatively affect other foods stored in the appliance.
- If you set an excessively low temperature for food, it may become frozen. Do not set a temperature lower than the required temperature for the food to be stored correctly.
- Always keep the appliance clean.

NOTE

- **Do not put living plants into the appliance.**

Max Freezing Capacity

- The Express Freeze function will allow the freezer to its maximum freezing capacity. This generally takes up to seven hours, however, it will automatically turn off after a given time and can also be turned off manually at any given time.
- To get better air circulation, insert all inner parts like baskets, drawers, and shelves.

Control Panel

Units and Functions

<Type 1>

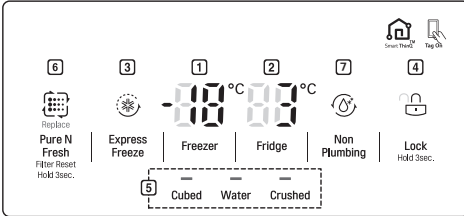

<Type 2>

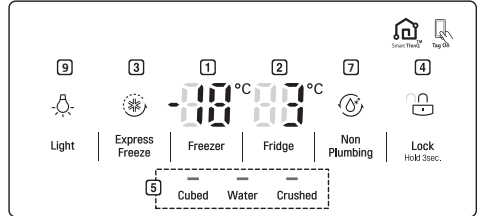

<Type 3>

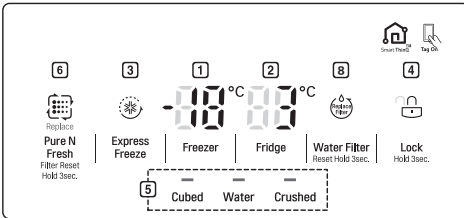

<Type 4>

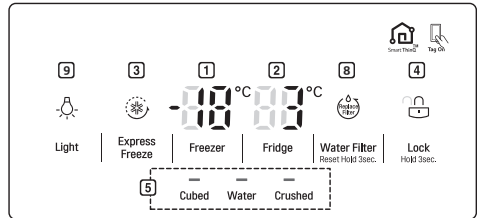

1 Freezer Temperature

- This sets the freezer target temperature

2 Fridge Temperature

- This sets the fridge target temperature.

3 Express Freeze

- This sets Express Freeze function.

4 Lock

- This locks the buttons on the control panel.

5 Water Dispenser

- This sets the function of Cubed ice, Water, Crushed ice.

6 Pure N Fresh (Optional)

- This sets the Pure N Fresh function.

7 Non Plumbing (Optional)

- This Non Plumbing icon is illuminated when the water dispenser tank is installed correctly.

8 Replacement Filter (Optional)

- This shows the replacement period of the water filter automatically (plumbed models only).

9 Light (Optional)

- This sets the Light function of the dispenser.
- The function is enabled and disabled in turn each time you press the Light button. However, in Energy Saving mode, the function will be set according to the operation sequence shown above.

- The actual control panel may differ from model to model.

Notes for Use the Control Panel

- The control panel will turn on in any of the following cases.
 - When the power is turned on
 - When a button is pressed
 - When the appliance door (fridge compartment, freezer compartment, Door in Door) is opened
- The control panel will turn off automatically for energy saving in any of the following cases.
 - When one minute has passed after turning on the power
 - When no button operation is carried out for 20 seconds after a desired button is pressed
 - When 20 seconds has passed after the appliance door (fridge compartment, freezer compartment, magic space) is opened and closed
- If there is any finger or skin contact to the control panel while cleaning it, the button function may operate.

Setting the Temperature

This sets the fridge temperature or freezer temperature.

- Press the **Fridge** button or **Freezer** button to adjust the temperature.
- The initial temperature of the fridge is set to 3 °C, and the temperature can be adjusted from 1 °C to 7 °C.
- The initial temperature of the freezer is set to -18 °C, and the temperature can be adjusted from -14 °C to -24 °C.
- The actual inner temperature varies depending on the food status, as the indicated setting temperature is a target temperature, not the actual temperature within the appliance.

NOTE

- Wait until two or three hours have passed after connecting the appliance to the outlet before storing food in the appliance.
- The appliance can automatically detect problems during the operation.
- If a problem is detected, the appliance does not operate and an error code is displayed even when any button is pressed.

- When this occurs, do not turn off the power and immediately contact an LG Electronics customer information centre. If you turn off the power, the repair technician from the LG Electronics customer information centre. It may have difficulty finding the problem.

Setting Express Freeze

The function can quickly freeze a large amount of ice or frozen foods.

- When you press the **Express Freeze** button, the **Express Freeze** icon lights on the control panel.
- The function is enabled and disabled in turn each time you press the button.
- The Express Freeze function automatically terminates after a specific period has passed.

Setting and Resetting Lock

This locks the buttons on the control panel.

- When you press the **Lock** button for three seconds, the set/reset icon on the control panel lights. The function is enabled and disabled in turn each time you press the button.
- If you press a button other than **Lock** when the child lock is set, the button will not function.
- When you press a button other than **Lock** when the child lock is set, the set/reset icon on the control panel will flash 3 times.
- To change a setting, first press the **Lock** button for three seconds to disable the function.

Setting Pure N Fresh (Optional)

Bacteria and odor inside the appliance can be minimized with the Pure N Fresh function. However, the function is only effective for bacteria floating in the appliance, not bacteria adsorbed onto food.

Setting Light (Optional)

This sets the Light function of the dispenser.

- When you press the **Light** button, the Light icon is illuminated on the control panel and the function is set. The function is enabled and disabled in turn each time you press the button.
- When lighting is set to the on position, the dispenser lamp will remain on regardless if water or ice is being dispensed.

Water Dispenser Tank (Non plumbed models only)

The water tank holds the water in which is to be dispensed or used by the automatic ice maker to make ice. Do not fill this tank with any other liquid other than water. Doing so can damage the water dispensing system.

- 1 Remove the water dispenser tank by pulling it out while holding the handle.

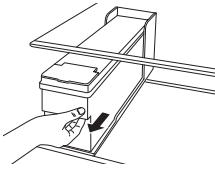

- 2 Open the cover or cap of the water dispenser tank.

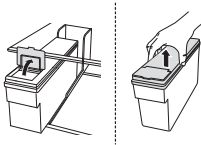

- 3 Fill with bottle filtered or clean filtered water up to the reference line indicated inside the water dispenser tank. (Total capacity: 4 l)

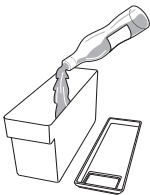

- 4 After filling with water, close the cover or cap of the water dispenser tank.

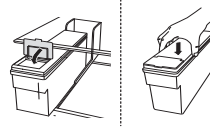

- 5 Refit the water dispenser tank in to the fridge shelf.

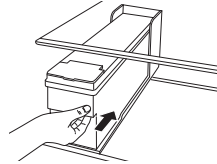

CAUTION

- Children should not be allowed near the dispenser tank. If the child drops the water dispenser tank while it is completely filled with water, injury may occur. Do not fill the water tank with drinks other than water or fill with hot water.
- Do not apply excessive force or impact when removing or assembling the water dispenser tank. Doing so can cause appliance damage or injury. Use both hands to remove and hold the water tank. The tank can be broken if it falls on to the floor.

NOTE

- Before using the water dispenser tank after installing the appliance, it should be washed before filling it with water.
- Check if the water dispenser tank has been placed in to the appliance correctly. If it is not assembled correctly, water may leak from the tank into the appliance.
- If there is an insufficient amount of water in the water dispenser tank, ice cube size and quantity may be affected and may result in no ice being made.
- If the water level is low, or there is no water in the water dispenser tank, the cold water and ice dispensing function of the dispenser cannot be used. Check if there is water in the water dispenser tank and then fill it if necessary.

- Wait at least 15 seconds before removing the water tank after having dispensed water or ice from the dispenser. Not doing so could cause an air lock.
- Sound from the water tank will be normal when supplying water to the dispenser and the Automatic Ice Maker. It is not a sign of malfunction.

Water and Ice Dispenser

You can dispense cubed ice, water or crushed ice by pressing the respective button for the desired mode.

- When you touch the **Cubed**, **Water** or **Crushed** button on the control panel, the lamp on the control panel will turn on and the desired mode will be set. At this time, when you press the dispenser lever, the selected appliance (cubed ice, water and crushed ice) will be dispensed,
- The function is enabled and disabled in turn each time you press the button on the control panel.

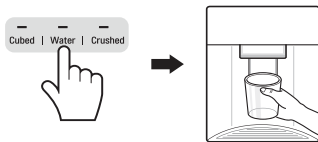

CAUTION

- Keep children away from the dispenser to prevent children playing with or damaging the controls.
- Throw away the first few batches of ice (about 20 cubes and 7 cups of water). This is also necessary if the appliance has not been used for a long time.

NOTE

- If you open the freezer door while water is being dispensed, the water supply will stop and the control panel will return to the initial screen.
- If you open the fridge door while water, cubed ice or crushed ice is being dispensed, dispensing will be paused. When you close the door, the selected item for the previously set mode will continue to be dispensed.
- If the cup rim is small, water may splash out of the glass or miss it completely.
- Use a cup with a rim of over 68 mm in diameter when dispensing water, cubed ice or crushed ice.
- When the ice maker produces smaller ice cubes, or the cubes become lumped together, the amount of water supplied to the ice maker may be low due to insufficient water in the water tank. If ice is not used frequently, it may also lump together.

Automatic Icemaker

The automatic icemaker can automatically make 6 cubes at a time, 50~60 pieces within a 24hr period if conditions are favorable. This amount may vary according to the environment (ambient temperature around the appliance, frequency of the door being opened, amount of food stored in the appliance, etc.).

- If the ice bin is completely filled with ice, ice production will stop.
- Sound of ice dropping into the ice bin is normal.
- The icemaker produces ice normally when approximately 48 hours have passed after the appliance is initially installed.
- Discard ice produced for the first time without using it.
- While the automatic icemaker is operating, do not touch it with your hands directly.
- If ice cubes are stored in the ice bin for a long period of time, they may clump together and may not be separated easily. In such a case, clean the ice bin before using it.

Switching the Automatic Icemaker On and Off

- 1 Hold and remove the cover of the automatic icemaker by lifting it upward.

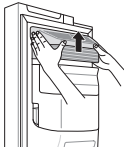

- 2 When the automatic icemaker is not used, the ice bin can be used as a freezer basket after selecting the icemaker switch to the off position.

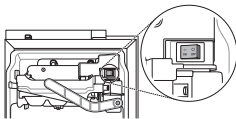

Removing the Ice Bin (Optional)

Hold the ice bin with both hands and pull it out while lifting it upward.

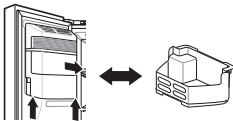

- When the automatic icemaker is not used, the ice bin can be used as a freezer basket.
- If the ice bin is completely filled with ice, it may be heavy. Remove it using both hands.

WARNING

- Do not touch the automatic icemaker mechanical parts with your hand or a tool. Otherwise, appliance damage or injury may occur.
- Caution should be taken, as the automatic icemaker operates continuously after the freezer door is opened when the automatic icemaker switch is set to the on position.

- Do not disassemble, repair or alter the automatic icemaker. These tasks should only be done by a service technician.

CAUTION

- Throw away the first few batches of ice (about 20 cubes and 7 cups of water). This is also necessary if the appliance has not been used for a long time.
- The first ice and water dispensed may include particles or odor from the water supply line or the water tank.
- Keep children away from the dispenser. Children may play with or damage the controls.
- The ice passage may become blocked with frost if only crushed ice is used. Remove the frost that accumulates by removing the ice bin and clearing the passage with a rubber spatula. Dispensing cubed ice periodically can also help prevent frost buildup.
- If discolored ice is dispensed, check the water tank and the water supply for a possible source. If the problem continues, contact the LG Electronics customer information centre. Do not use the ice or water until the problem is corrected.
- Never use thin crystal glass or crockery to collect ice. Such containers may chip or break resulting in glass fragments in the ice.
- Dispense ice into a glass before filling it with water or other beverages. Splashing may occur if ice is dispensed into a glass that already contains liquid.
- Do not touch the ice outlet or the automatic icemaker with your hand or a tool. Otherwise, appliance damage or injury may occur.
- When refitting the ice bin, ensure it is placed correctly. If it is tilted or unlevelled, it may not continue to make ice due to sensor disruption.
- Never use a glass that is exceptionally narrow or deep. Ice may jam in the ice passage and appliance performance may be affected.
- Keep the glass at a proper distance from the ice outlet. A glass held too close to the outlet may prevent ice from dispensing.
- Dispose of the ice inside the ice bin in the freezer compartment if you go out on vacation or an extended power outage occurs. Water from melting ice may drop from the dispenser onto the floor.

Door in Door (Optional)

Press the lever on the lower edge door in door until it opens.

There is plenty of storage space inside the door in door and its surrounding baskets, allowing you to store food in an organized manner.

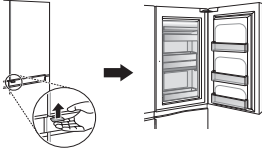

Removing the Case from the Door in Door

Hold the case from inside the door in door with both hands and remove it by lifting it upward.



Refitting the Door in Door Case

Mount them in the reverse order of the removal process.

Removing the Baskets from the Door in Door

- 1 Hold both edges of the basket and remove it by lifting it upward.

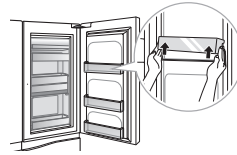

- 2 Lift the fixed basket up as shown in ① and remove it by pulling it out as shown in ②.

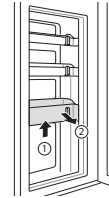

Refitting the Baskets to the Door in Door Hombar

Mount them in the reverse order of the removal process.

Fresh Vegetable Drawer (Optional)

The Humidity in the vegetable crisper drawer can be controlled by sliding the lever in either direction.

If moved to the left side, the air guide will be open and allow air to circulate through the drawer for reduced humidity. And if moved to the right side, the air guide will be closed and will maintain any humidity that is currently in the crisper drawer.

The closed state is recommended for storing vegetables, and open state is recommended for storing fruit.

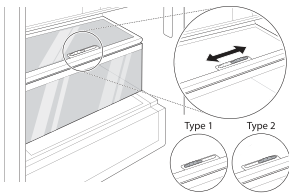

Other Functions

Door Open Alarm

The alarm sounds 3 times in 30 second intervals if any one of the appliance's doors are left open for longer than 1 minute.

- Contact an LG Electronics customer information centre if the alarm sound continues after 30 seconds even after closing the door.

Malfunction Detection

The appliance can automatically detect certain problems during the operation.

- If a problem is detected, or the appliance does not operate an error code is displayed even when any button is pressed.
- When this occurs, do not turn off the power but immediately contact an LG Electronics customer information centre. If you turn off the power, the repair technician from an LG Electronics customer information centre may have difficulty finding the problem.

SMART FUNCTION

Application Installation

Search for the LG Smart ThinQ application from the Google Play Store on a smart phone. Follow instructions to download and install the application.

Product Registration

- 1 Run the LG Smart ThinQ application on a smart phone.
- 2 Create an account and sign in.
- 3 Select **Register**.
- 4 Select **Refrigerator**.
- 5 Follow the instruction on the smart phone.
 - If the NFC function is not turned on, turn on the NFC function in the smart phone.
- 6 Firmly attach the smart phone to the Tag On logo on the appliance.
 - If you can not make a connection, then move the smart phone up and down slowly.

NOTE

- Press ? in the LG Smart ThinQ application for a more detailed guide on how to use the Tag On function.
- To operate the NFC function on this product will require a smart phone which has at least a certain level of NFC function recognition. Because of the characteristics of NFC, if the transmission distance is too far, or if there is a metal sticker or a protective case on the phone, transmission will not be good. In some cases, NFC-equipped phones may be unable to transmit successfully.
- The content found in this manual may differ from the current version of the LG Smart ThinQ application, and the software may be modified without informing customers.
- NFC function will vary depending on the smart phone.

Using the Tag On Function

Conveniently use the Smart Diagnosis™ to communicate with the appliance directly from a smart phone.

The Tag On function can only be used with most smart phones equipped with the NFC (Near Field Communication) function and based on the Android OS (operating system).

Using the Application

Select the appliance from the Dashboard to use the desired functions by touching the LG appliance's Tag On logo with an NFC-equipped smart phone.

Smart Diagnosis™

If you use the Smart Diagnosis function, you will be provided with the useful information such as a correct way of using the appliance based on the pattern of use.

Using Smart Diagnosis™

Use this function if you need an accurate diagnosis by an LG Electronics customer information centre when the appliance malfunctions or fails.

Smart Diagnosis™ can not be activated unless the appliance is connected to power. If the appliance is unable to turn on, then troubleshooting must be done without using Smart Diagnosis™..

Smart Diagnosis™ Using a Smart Phone

- 1 Open the LG Smart ThinQ application on the smart phone.
- 2 Select the refrigerator in dashboard.
- 3 Press **Start Smart Diagnosis** button.
- 4 Follow the instructions on the smart phone.

NOTE

- If the diagnosis is continually unsuccessful, then use the following instructions.

- 5 Select the **Audible Diagnosis**.
- 6 Follow the instructions on the smart phone.
- 7 Keep the phone in place until the tone transmission has finished. View the diagnosis on the phone.

NOTE

- The Smart Diagnosis™ function depends on the local call quality.
- The communication performance will improve and you can transmit a better signal if you use a land line home phone.
- If the Smart Diagnosis™ data transfer is poor due to poor call quality, you may not receive the best Smart Diagnosis™ service.

Smart Diagnosis™ Through the Customer Information Centre

Use this function if you need an accurate diagnosis by an LG Electronics customer information center when the appliance malfunctions or fails. Use this function only to contact the service representative, not during normal operation.

- 1 Press the **Lock** button to activate the Lock function.
 - If the Lock function has been activated already, press the **Lock** button to deactivate the Lock function, and then press the **Lock** button again to activate the Lock function.
 - Please note that the Smart Diagnosis function will not operate until five minutes has passed since the Lock function was activated.



- 2 Open the fridge door and then hold the phone on the upper right speaker hole.
 - Position the phone so that its microphone is aligned with the speaker hole.

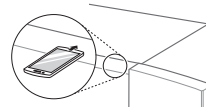

- 3 Press and hold the **Freezer** button for three seconds or longer while continuing to hold your phone to the speaker.



- 4** Keep the phone on the speaker hole in the upper right corner.
 - Position the phone so that its microphone is aligned with the speaker hole.
 - The Smart Diagnosis™ sound is generated after around three seconds.
 - Do not take the phone off the speaker hole while the data is transmitted.
 - Hold the phone to the upper right speaker hole and wait while the data is transmitted.
 - The data transfer sound may be harsh to the ear while the Smart Diagnosis™ data is being transmitted, but do not take the phone off the speaker hole for accurate diagnosis until the data transfer sound has stopped.
- 5** After the data transfer is complete, the service agent will explain the result of the Smart Diagnosis™.
 - When the data transfer is complete, the transfer completion message is displayed and the control panel is automatically turned off and then on again after a few seconds. After the customer information centre explains the diagnosis result.

NOTE

- The Smart Diagnosis™ function depends on the local call quality.
- The communication performance will improve and you can transmit a better signal if you use a land line home phone.
- If the Smart Diagnosis™ data transfer is poor due to poor call quality, you may not receive the best Smart Diagnosis™ service.

MAINTENANCE

Notes for Cleaning

- When removing a shelf or drawer from inside the appliance, remove all stored foods.
 - Otherwise, injury may occur due to the weight of stored foods.
- If cleaning the outside air vents of the appliance by means of vacuuming, then the power cord should be unplugged from the outlet to avoid any static discharge that can damage the electronics or cause an electric shock.
- Detach the shelves and drawers and clean them with water, and then dry them sufficiently, before replacing them.
- Regularly wipe the door gasket with a wet soft towel.
- Door basket spills and stains should be cleaned as they can compromise storage ability of the basket and could even be damaged.
- After cleaning, check if the power cable is damaged, warm or improperly plugged.
- Keep the air vents on the exterior of the appliance clean.
 - Blocked air vents can cause fire or appliance damage.
- Waxing external painted metal surfaces helps provide rust protection. Do not wax plastic parts. Wax painted metal surfaces at least twice a year using appliance wax (or auto paste wax). Apply wax with a clean, soft cloth.
- For the appliance exterior, use a clean sponge or soft cloth and a mild detergent in warm water. Do not use abrasive or harsh cleaners. Dry thoroughly with a soft cloth.
- Never clean the shelves or containers in the dishwasher.
 - The parts may become deformed due to the heat.
- If the appliance is equipped with an LED lamp, do not remove lamp cover and LED lamp in any attempt to repair or service it. Please, contact an LG Electronics customer information centre.

Replacing the Pure N Fresh Filter (Optional)

To maintain the performance of the Pure N Fresh filter, if a message indicating the filter replacement is displayed, replace the filter as soon as possible.

- 1 If **Replace** icon lights on the control panel, replace the Pure N Fresh filter.

Replace

**Pure N
Fresh**

Filter Reset
Hold 3sec.

- 2 Hold and remove the Pure N Fresh filter cover by rotating it counterclockwise.



- 3 Remove the filter inside the Pure N Fresh filter cover and replace it with a new filter.



- 4 After replacing the filter, insert the Pure N Fresh filter cover by rotating it clockwise.

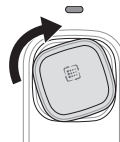

- 5 To reset the filter replacement period, press the **Pure N Fresh** button on the control panel for more than three seconds. The **Replace** icon on the control panel will turn off.

- 6 It will then operate after replacing the filter.

NOTE

- Do not insert your finger or other foreign objects inside the filter or its mounting. Doing so may result in injuries or malfunctions.
- If the replacement period has passed, the bacteria and odor removal performance may be compromised.
- Please note that if you wash the filter with water, the filter performance may also deteriorate.
- Caution should be taken not to change the direction of the filter to be inserted into the filter cover.
- The filter can be purchased from an LG Electronics customer information centre.

Cleaning the Door Basket

Removing the Fridge/Freezer Door Basket

Hold both edges of the basket and remove it by lifting it upward.

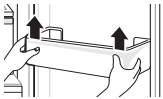

Refitting the Fridge/Freezer Door Basket

- 1 Hold both edges of the door basket, gently push one edge to align it in place, and then in the same manner align the other edge.

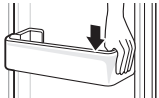

- 2 After aligning it, tap on the door basket gently to secure it to its horizontal position.

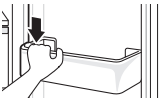

Cleaning the Shelf

Removing the Fridge/Freezer Shelf

Remove the shelf by pulling it out.

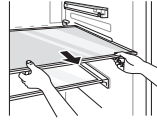

Refitting the Fridge/Freezer Shelf

Mount them in the reverse order of the removal process.

Cleaning the Vegetable Drawer

Removing the Vegetable Drawer

- 1 Remove the contents of the drawer. Hold the handle of the vegetable drawer and pull it out completely until it outward gently until it stops.

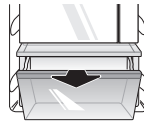

- 2 Lift the vegetable drawer up and remove it by pulling it out.

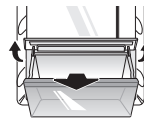

Refitting the Vegetable Drawer

- 1 If the vegetable drawer has a cover, lift it..

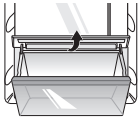

- 2 Insert the bottom of the vegetable drawer into its original position and gently push it back in while lowering it.

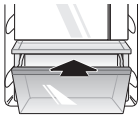

CAUTION

- Please note that injuries can be caused by the weight of stored foods when removing the vegetable drawer if they are not removed.

Cleaning the Water Dispenser

Cleaning the Dispenser Tray

The dispenser tray may become wet easily due to spilled ice or water. Wipe the entire area with a damp cloth.



Cleaning the Water and Ice Outlet

Wipe the water or ice outlet frequently with a clean cloth as it may get dirty easily. Please note that lint from a cloth may adhere to the outlet.

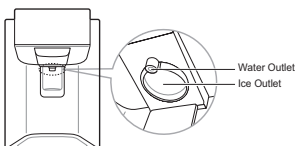

Replacing the Water Filter (For Plumbed models Only)

Replace the disposable water filter when indicated on the **Replacement Filter** icon or at least every 6 months.

To give you preparation time to get a new filter, the light will come on just before the capacity of the current filter runs out. Changing the filter on time provides you with the fresh and clean water from the appliance.

- 1 Unplug the appliance.
- 2 Turn off the water supply to the appliance.
- 3 Remove the disposable water filter.
- 4 Install the replacement water filter by following the 'Connecting to the Water Filter' section.
- 5 Turn on the water supply and switch on the appliance.
- 6 Press and hold the **Water Filter** button for three seconds. This will reset the Replacement Filter icon. The new water filter has been activated. Water from a new filter will appear cloudy until several liters are dispensed. The cloudiness is an accumulation of microscopic air bubbles and is safe to drink.

NOTE

- To purchase a replacement water filter, contact an LG Electronics service centre.

TROUBLESHOOTING

Symptoms	Reason	Solution
There is no refrigeration or freezing.	Is there a power interruption?	<ul style="list-style-type: none"> • Check the power of other appliances.
	If the power plug unplugged from the outlet?	<ul style="list-style-type: none"> • Plug the power plug in the outlet properly.
There is poor refrigeration or freezing.	Is the fridge or freezer temperature set to its warmest setting?	<ul style="list-style-type: none"> • Set the fridge or freezer temperature to 'Medium' or cooler and re check after 24Hrs
	Is the appliance in direct sunlight, or is it near a heat generating object such as cooking oven or heater?	<ul style="list-style-type: none"> • Check the installation area and reinstall it away from heat generating objects.
	Did you store hot food without cooling it first?	<ul style="list-style-type: none"> • Cool the hot food first before putting it in the fridge or freezer compartment.
	Did you put in too much food?	<ul style="list-style-type: none"> • Maintain an appropriate space between food.
	Are the appliance doors completely closed?	<ul style="list-style-type: none"> • Completely close the door and make sure that stored food is not obstructing the door.
	Is there enough space around the appliance?	<ul style="list-style-type: none"> • Adjust the installation position to make enough space around the appliance.
The appliance contains a bad smell.	Is the fridge or freezer temperature set to 'Warm'?	<ul style="list-style-type: none"> • Set the fridge or freezer temperature to 'Medium'.
	Did you put in food with a strong smell?	<ul style="list-style-type: none"> • Store foods with strong smells in sealed containers.
	Vegetables or fruit may have spoiled in the drawer?	<ul style="list-style-type: none"> • Throw away rotten vegetables and clean the vegetable drawer. Do not store vegetables too long in the vegetable drawer.
The inside lamp in the appliance does not turn on.	Does the inside lamp in the appliance turn off?	<ul style="list-style-type: none"> • It is hard for customers to replace the inside lamp in the appliance as they are not serviceable. If the inside lamp does not turn on, please contact the LG Electronics customer information centre.

Symptoms	Reason	Solution
The appliance door is not closed tightly.	Is the appliance leaning forward?	<ul style="list-style-type: none"> Adjust the front feet to raise the front side slightly.
	Were the shelves properly assembled?	<ul style="list-style-type: none"> Refit the shelves if needed.
	Did you close the door with excessive force?	<ul style="list-style-type: none"> If you apply too much force or speed when closing the door, it may remain briefly open before closing. Make sure that you do not slam the door closed. Close without force.
It is difficult to open the appliance door.	Did you open the door right after you closed it?	<ul style="list-style-type: none"> If you try to open the appliance door within one minute after you closed it, you may have difficulties because of the pressure inside the appliance. Try to open the appliance door again in a few minutes so that the internal pressure stabilizes.
There is condensation inside the appliance or on the bottom of the vegetable drawer cover.	Did you store hot food without cooling it first?	<ul style="list-style-type: none"> Cool the hot food first before putting it in the fridge or freezer compartment.
	Did you leave the appliance door open?	<ul style="list-style-type: none"> Although the condensation will disappear soon after you close the appliance door, you can wipe it with a dry cloth.
	Do you open and close the appliance door frequently?	<ul style="list-style-type: none"> Condensation can form due to the temperature difference from the outside. Wipe out the dampness with a dry cloth.
	Did you put warm or moist food inside without sealing it in a container?	<ul style="list-style-type: none"> Store food in a covered or sealed container.
Frosts has formed in the freezer compartment.	Doors may not be closed properly?	<ul style="list-style-type: none"> Check if the food item inside the appliance is blocking the door and make sure that the door is tightly closed.
	Did you store hot food without cooling it first?	<ul style="list-style-type: none"> Cool the hot food first before putting it in the fridge or freezer compartment.

Symptoms	Reason	Solution
Frosts has formed in the freezer compartment.	Is the air entry or exit of the freezer compartment blocked?	<ul style="list-style-type: none"> Make sure that air entry or exit is not blocked so that the air can circulate inside.
	Is the freezer compartment overfilled?	<ul style="list-style-type: none"> Maintain an appropriate space between items.
Frost or condensation has formed inside or outside the appliance.	Did you open and close the appliance door frequently or is the appliance door improperly closed?	<ul style="list-style-type: none"> Frosts or condensation can form if the outside air penetrates inside the appliance.
	Is the installation environment humid?	<ul style="list-style-type: none"> Condensation can appear on the exterior of the appliance if the installation area is too humid or on a humid day such as a rainy day. Wipe off any moisture with a dry cloth.
The appliance is noisy and generates abnormal sounds.	Is the appliance installed on a weak floor or improperly leveled?	<ul style="list-style-type: none"> Install the appliance on a solid and flat area.
	Does the rear of the appliance touch the wall?	<ul style="list-style-type: none"> Adjust the installation position to allow enough clearance around the appliance.
	Are objects scattered behind the appliance?	<ul style="list-style-type: none"> Remove the scattered objects from behind the appliance.
	Is there an object on top of the appliance?	<ul style="list-style-type: none"> Remove the object on top of the appliance.
The side or front of the appliance is warm.	There are anti condensation pipes fitted to these areas of the appliance to reduce condensation forming from around the door area.	<ul style="list-style-type: none"> The heat releasing pipe to prevent condensation is installed on the front and side of the appliance. You may feel it particularly hot right after the appliance is installed or during the summer. You can be assured that this is not a problem and is quite normal.
There is water inside or outside of the appliance.	Is there water leakage around the appliance?	<ul style="list-style-type: none"> Check if the water has leaked from a sink or another place.
	Is there water on the bottom of the appliance?	<ul style="list-style-type: none"> Check if the water is from the thawed frozen food or a broken or dropped container.

Symptoms	Reason	Solution
The automatic icemaker does not produce ice or produces a small amount of ice.	Did you install the appliance recently?	<ul style="list-style-type: none"> The ice maker produces ice normally when approximately 48 hours have passed after the appliance is installed.
	Did you connect the water supply pipe to the appliance and open the supply valve?	<ul style="list-style-type: none"> Connect the water supply pipe to the appliance and open the supply valve completely.
	Is the water supply hose bent?	<ul style="list-style-type: none"> If the water supply hose is bent, the water flow could be compromised.
	Have you dispensed a large amount of ice recently?	<ul style="list-style-type: none"> It takes approximately 24 hours to produce more ice in the automatic icemaker. Please wait.
	Did you set the ice maker switch or the automatic icemaker button on the control panel to ON?	<ul style="list-style-type: none"> Press I on the automatic icemaker switch or set ON for the automatic icemaker button on the control panel. (For more details on how to use, visit LG electronics website or use your smart device.)
The automatic icemaker does not produce ice or produces a small amount of ice.	Is the temperature of the freezer compartment set too high?	<ul style="list-style-type: none"> If the set temperature is too warm, ice will be produced slowly or not at all. Set the Freezer temperature to -18 °C for normal operation of the automatic icemaker.
	Have you been opening the appliance door frequently?	<ul style="list-style-type: none"> If you open the appliance door frequently, cold air will escape, lowering the speed of ice production. Do not open and close the appliance door frequently.
	Is the appliance door completely closed?	<ul style="list-style-type: none"> If the appliance door is not completely closed, the temperature of the freezer compartment will increase, slowing down the ice production speed. Close the appliance door completely.
	Is the water tank filled with water(non plumbed models only)	<ul style="list-style-type: none"> Fill the water tank with water.

Symptoms	Reason	Solution
Water does not come out.	The supply valve may be turned off? (For Plumbed models Only)	<ul style="list-style-type: none"> • Open the water supply valve.
	The water dispenser tank may be empty? (Non plumbed models only)	<ul style="list-style-type: none"> • Fill the water dispenser tank.
	Is the water supply valve closed? (For Plumbed models Only)	<ul style="list-style-type: none"> • Open the water supply valve.
	Are you using unfiltered water?	<ul style="list-style-type: none"> • Unfiltered water can contain a large amount of various heavy metals or foreign substances, so the filter may be clogged in the early stage regardless of the life of the filter.
Water tastes strange.	Is the taste of water different when comparing it with the taste of water from the previous water purifier?	<ul style="list-style-type: none"> • You may notice a difference in the taste of water according to the raw materials used to make the filter in each company. However, it is not a sign of malfunction.
	Has it been a long time since you installed and replaced the filter?	<ul style="list-style-type: none"> • If an expired filter is used, the purification performance may decline. It is recommended to replace the filter according to the filter replacement period.
	Have you flushed out the filter properly in the initial stage after installing it?	<ul style="list-style-type: none"> • When you install or replace the filter for the first time, you need to remove air and activated carbon residue from inside the filter. Use the appliance after dispensing and discharging approximately 5 litres of purified water from the dispenser by pressing the water dispensing lever. (Activated carbon is harmless to humans.)
	Has the purified water or cold water not been used for an extended period of time?	<ul style="list-style-type: none"> • The taste of old water may change due to bacterial growth. Use the product after dispensing and discharging approximately 5 litres (approximately three minutes) from the water dispenser.

Symptoms	Reason	Solution
Clicking noises	The defrost control will click when the automatic defrost cycle begins and ends. The thermostat control (or appliance control on some models) will also click when cycling on and off.	<ul style="list-style-type: none"> • Normal Operation
Rattling noises	Rattling noises may come from the flow of refrigerant, the water line on the back of the unit (for plumbed models only), or items stored on top of or around the appliance.	<ul style="list-style-type: none"> • Normal Operation
	Appliance is not resting evenly on the floor.	<ul style="list-style-type: none"> • Floor is weak or uneven or leveling legs need to be adjusted. See the door alignment section.
	Appliance with linear compressor was moved while operating.	<ul style="list-style-type: none"> • Normal operation. If the compressor does not stop rattling after three minutes, turn the power to the appliance off and then on again.
Whooshing noises	Evaporator fan motor is circulating air through the fridge and freezer compartments.	<ul style="list-style-type: none"> • Normal Operation
	Air is being forced over the condenser by the condenser fan.	<ul style="list-style-type: none"> • Normal Operation
Gurgling noises	Refrigerant flowing through the cooling system	<ul style="list-style-type: none"> • Normal Operation
Popping noises	Contraction and expansion of the inside walls due to changes in temperature.	<ul style="list-style-type: none"> • Normal Operation
Vibrating	If the side or back of the appliance is touching a cabinet or wall, some of the normal vibrations may make an audible sound.	<ul style="list-style-type: none"> • To eliminate the noise, make sure that the sides and back do not make any contact with any wall or cabinet.

