

# Breville®

## Breville Customer Service Centre

### Australian Customers

**Mail:** PO Box 22  
Botany NSW 2019  
AUSTRALIA

**Phone:** 1300 139 798

**Fax:** (02) 9384 9601

**Email:** Customer Service:  
askus@breville.com.au

### New Zealand Customers

**Mail:** Private Bag 94411  
Botany Manukau 2163  
Auckland NEW ZEALAND

**Phone:** 0800 273 845

**Fax:** 0800 288 513

**Email:** Customer Service:  
askus@breville.co.nz

[www.breville.com.au](http://www.breville.com.au)

[www.breville.co.nz](http://www.breville.co.nz)

Breville is a registered trademark of Breville Pty. Ltd. A.B.N. 98 000 092 928.  
Copyright Breville Pty. Ltd. 2014.

Due to continued product improvement, the products illustrated/photographed  
in this brochure may vary slightly from the actual product.

**BOV845 ANZ A14**

# Breville®

*the Smart Oven® Pro*

Instruction Booklet



Suits all BOV845 models

- 3** Breville recommends safety first
- 6** Know your Breville product
- 8** Quick Start Guide
- 10** Operating your Breville product
  - 11 - GRILL function
  - 12 - TOAST function
  - 13 - CRUMPET function
  - 15 - BAKE function
  - 16 - ROAST function
  - 17 - PIZZA function
  - 19 - COOKIES function
  - 20 - REHEAT function
  - 21 - WARM function
  - 22 - SLOW COOK function
- 24** Care, cleaning and storage
- 27** Troubleshooting
- 29** Recipes

At Breville we are very safety conscious. We design and manufacture consumer products with the safety of you, our valued customer, foremost in mind. In addition we ask that you exercise a degree of care when using any electrical appliance and adhere to the following precautions.

## **IMPORTANT SAFEGUARDS**

### **READ ALL INSTRUCTIONS CAREFULLY BEFORE USE AND SAVE FOR FUTURE REFERENCE**

When using electrical appliances, basic safety precautions should always be followed including:

- Remove and safely discard any packing materials and promotional labels before using the oven for the first time.
- To avoid choking hazard for young children, remove and safely dispose the protective cover fitted on the power plug.
- Do not use the appliance near the edge of a benchtop or table. Ensure the surface is stable, level, heat-resistant and clean.
- Do not use on a cloth-covered surface, near curtains or other flammable materials.
- A fire may occur if the oven is covered or touches flammable material, including curtains, draperies, walls, and the like, when in operation.
- Do not use the appliance on (or close to) a hot gas or electric burner, or where it could touch a heated oven or surface.
- Do not let the power cord hang over the edge of a table or counter, or touch hot surfaces.
- To avoid electric shock, do not immerse the cord, plug or motor base in water (or other liquids).
- When operating the oven, keep a minimum distance of 10cm of space on both sides of the appliance and 15cm above.
- The temperature of accessible surfaces may be high when the appliance is operating.
- Do not touch hot surfaces. To avoid burns, use extreme caution when removing pans, dishes and accessories such as the included grilling rack and baking pan, that contain hot oil or other hot liquids.
- Do not lay cooking utensils, baking pans or dishes on the glass door.
- Do not leave the door standing open for extended periods of time.
- Do not store any item on top of the oven when in operation except those described on page 24 of this book.
- Do not place cardboard, plastic, paper, or other flammable materials in the oven.
- Do not cover crumb tray or any part of the oven with metal foil. This will cause overheating of the oven.
- Caution should be exercised when using pans and dishes constructed of materials other than metal. Ensure pans and dishes are oven safe before using in the oven.
- Caution should be exercised when using lids in the oven, as pressure build up in a covered pan or dish may cause hot ingredients to expel or the dish to crack. Do not place sealed or airtight containers in the oven.
- Oversized foods and metal utensils must not be inserted in the oven as they may create fire or risk of electric shock.
- The use of accessories and attachments not recommended or supplied with this oven may cause injuries.
- This appliance is for household use only. Do not use in any type of moving vehicles. Do not use the appliance outdoors, or for anything other than its intended use. Misuse can cause injury.

- If the appliance is to be: left unattended, cleaned, moved, assembled or stored, always switch the unit off and unplug the cord from the power outlet and allow to cool completely.
- Do not clean with metal scouring pads. Pieces can break off the pad and touch electrical parts, creating a risk of electric shock.
- This appliance is not intended for use by persons (including children) with reduced physical, sensory or mental capabilities, or lack of experience and knowledge, unless they have been given supervision or instruction concerning the use of the appliance by a person responsible for their safety.
- Children should be supervised to ensure that they do not play with the appliance.
- It is recommended to regularly inspect the appliance and power cord. Do not use the appliance if there is damage to the power cord or plug, or after the appliance malfunctions or has been damaged in any way. Immediately stop use and call Breville Customer Service.
- The appliance is not intended to be operated by means of external timer or separate remote control system.

## SPECIFIC INSTRUCTIONS FOR BOV845

- We recommend the oven is operated on a dedicated circuit separated from other appliances. Consult a licensed and qualified electrician if you are unsure.
- To turn off the oven, press the START/CANCEL button on the control panel. The oven is off when the button backlights turns off.
- Regularly clean the crumb tray. To clean the crumb tray:
  - Turn OFF the oven,
  - Allow the oven to cool completely and then remove the power cord from the power outlet.
  - Remove the crumb tray and clean with warm soapy water.
  - Dry the tray completely before inserting it securely back in place.



**WARNING**

*To reduce the risk of FIRE, ELECTRIC SHOCK, EXPOSURE TO EXCESSIVE UV RADIATION, OR INJURY TO PERSONS:*

- Always unplug the oven and let all parts (including the bulb housing, glass cover and enclosure) cool completely before replacing bulb.
- Only use a 25 Watt, 220–240V, G9 type oven bulb.
- Always use a soft cloth when handling the bulb and do not directly touch the surface as oil from your skin can damage the bulb.
- Do not look directly at a glowing bulb.
- Do not remain in the light if skin feels warm.
- Keep bulb away from materials that may burn.
- The bulb gets hot quickly. Only ever use the light button to turn on the light.
- Do not operate the light if the bulb housing, glass cover, UV filter or enclosure are missing or damaged.

**BREVILLE ASSIST® PLUG**

Your Breville appliance comes with a unique Assist® Plug, conveniently designed with a finger hole to ease removal from the power outlet.

**FOR HOUSEHOLD USE ONLY  
SAVE THESE INSTRUCTIONS**

## KNOW YOUR BREVILLE PRODUCT

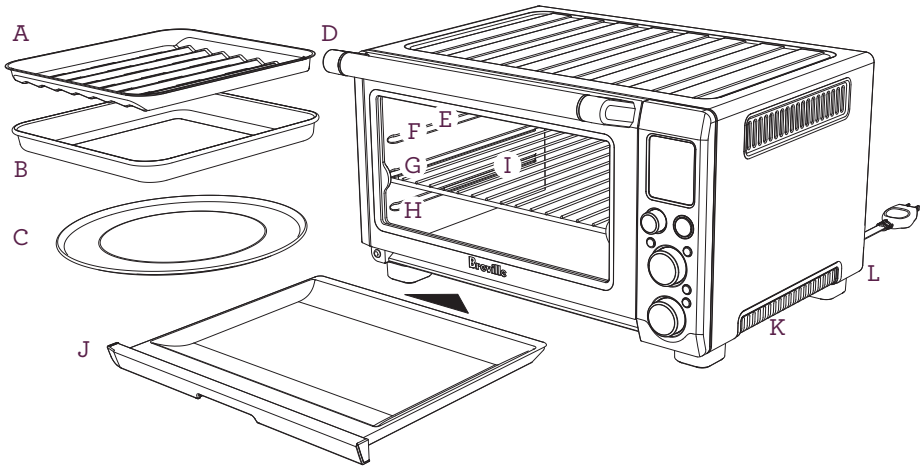



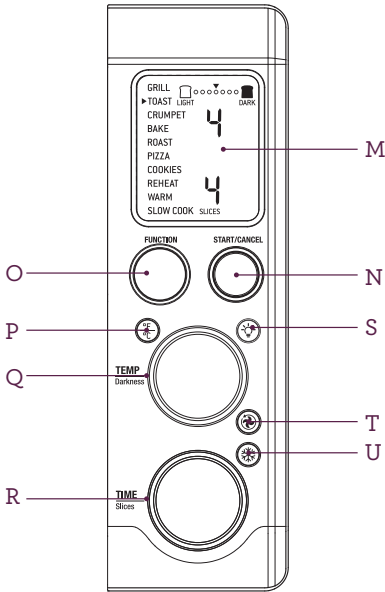

- A. 30 x 30cm enamel grilling rack
- B. 30 x 30cm enamel baking pan
- C. 33cm non-stick pizza pan
- D. Door handle
- E. Oven light
- F. Top rack height position:  
GRILL function
- G. Middle rack height position:  
TOAST, CRUMPET, PIZZA and  
COOKIES functions

- H. Bottom rack height position:  
BAKE, ROAST, REHEAT, WARM and  
SLOW COOK functions
- I. Wire rack
- J. Crumb tray
- K. Ventilation slots
- L. Breville Assist® Plug

## KNOW YOUR BREVILLE PRODUCT



- M. LCD screen
- N. START/CANCEL button
- O. FUNCTION dial
- P.  TEMPERATURE conversion button
- Q. TEMPERATURE dial/toast and crumpet darkness control
- R. TIME dial/toast and crumpet slice selection
- S.  OVEN LIGHT button
- T.  CONVECTION button
- U.  FROZEN FOODS button

Accessories sold separately:



Bamboo Cutting Board  
Part No: BOV800CB



33cm Non-Stick Pizza Crisper  
Part No. BOV800PC13



33cm Pizza Stone  
Part No. BOV800PS13



# Quick Start Guide

This Quick Start Guide is designed for first time use.

For safety and more information, refer to the rest of the Instruction Book.

## PREPARING THE OVEN

In order to remove any protective substances on the heating elements, it is necessary to run the oven empty for 15 minutes. Ensure the area is well ventilated as the oven may emit vapours. These vapours are safe and are not detrimental to the performance of the oven.

1. Remove and safely discard any packing material, promotional labels and tape from the oven.
2. Remove the crumb tray, wire rack, grilling rack, baking pan and pizza pan from the polyfoam packaging. Wash them with a soft sponge in warm, soapy water then rinse and dry thoroughly.
3. Wipe the interior of the oven with a soft, damp sponge. Dry thoroughly.
4. Place the oven on a flat, dry surface. Ensure there is a minimum distance of 10cm of space on both sides of the appliance and 15cm above.
5. Insert the crumb tray into the oven.
6. Unwind the power cord completely and insert the power plug in to a grounded power outlet.
7. The oven alert will sound and the LCD screen will illuminate. The function options will appear with an indicator on the BAKE setting.

8. Turn the FUNCTION dial to the right until the indicator reaches the PIZZA function.

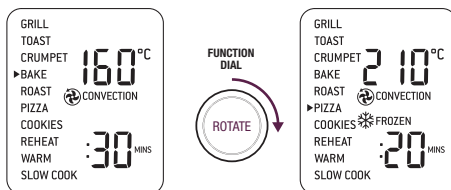

9. Press the START/CANCEL button. The button backlight will illuminate red, the LCD screen will illuminate orange and the oven alert will sound.
10. The LCD screen will indicate a blinking 'PREHEATING'. Once the oven has reached the set temperature, the temperature alert will sound.
11. The timer will be displayed and automatically begin to count down.
12. At the end of the cooking cycle, the oven alert will sound, the START/ CANCEL button backlight will go out and the LCD screen will illuminate blue.
13. The oven is now ready to use.

## QUICK START GUIDE

### ELEMENT IQ®

The Breville Smart Oven® Pro features Element IQ®, a cooking technology that adjusts the power of the heating elements to cook food more evenly and quickly. Each of the oven's functions is preset with our recommended setting, however we suggest experimenting with these depending on the recipe, amount of food and your personal taste.

Your customised setting will remain in the memory of the oven until changed or the oven is unplugged from the power outlet.

### OVEN FUNCTIONS OVERVIEW

FUNCTION	RACK POSITION	OPTIONAL SETTINGS	PRESETS	PREHEAT	RANGE
GRILL	Top	TEMPERATURE CONVERSION	HI 10 MINS	No	HI, MED, LO Up to 20 MINS
TOAST	Middle	FROZEN FOODS	Darkness 4 Slices 4	No	Darkness 1-7 Slices 1-6
CRUMPET	Middle	FROZEN FOODS	Darkness 4 Slices 4	No	Darkness 1-7 Slices 1-6
BAKE	Bottom	CONVECTION TEMPERATURE CONVERSION	160°C CONVECTION 30 MINS	Yes	50°C-230°C Up to 10:00 HRS
ROAST	Bottom	CONVECTION TEMPERATURE CONVERSION	175°C CONVECTION 1:00 HRS	Yes	50°C-230°C Up to 10:00 HRS
PIZZA	Middle	CONVECTION TEMPERATURE CONVERSION FROZEN FOODS	210°C CONVECTION FROZEN FOODS 20 MINS	Yes	50°C-230°C Up to 2:00 HRS
COOKIES	Middle	CONVECTION TEMPERATURE CONVERSION FROZEN FOODS	175°C CONVECTION 11 MINS	Yes	50°C-230°C Up to 1:00 HRS
REHEAT	Bottom	CONVECTION TEMPERATURE CONVERSION	165°C CONVECTION 15 MINS	No	50°C-230°C Up to 2:00 HRS
WARM	Bottom	CONVECTION TEMPERATURE CONVERSION	70°C 1:00 HRS	No	50°C-230°C Up to 2:00 HRS
SLOW COOK	Bottom	CONVECTION	HI CONVECTION 4:00 HRS	Yes	HI, 4:00 - 6:00 HRS LO, 8:00 - 10:00 HRS Automatic KEEP WARM Up to 2:00 HRS

### OPERATING YOUR BREVILLE OVEN

1. Position the wire rack so the spokes face upward and insert it into the desired rack position. The rack positions are conveniently printed on the right-hand side of the oven door window.

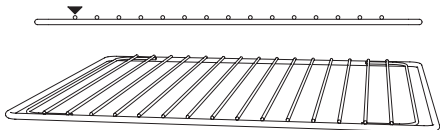

2. Turn the FUNCTION dial until the indicator on the LCD screen reaches the desired setting.
3. The top figure on the LCD screen indicates the preset cooking temperature for the selected setting. For the TOAST and CRUMPET settings it indicates the darkness level. Turn the TEMPERATURE dial to the left to reduce the temperature or to the right to increase the temperature.

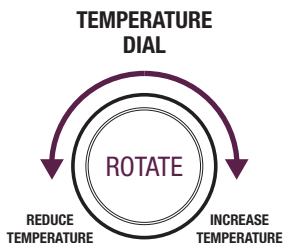

4. The bottom figure on the LCD screen indicates the preset cooking time for the selected setting. For the TOAST and CRUMPET settings it indicates the number of slices. Turn the TIME dial to the left to reduce the cooking time or to the right to increase the cooking time.

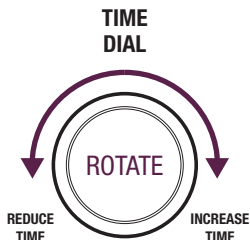

5. For settings without a preheat cycle (TOAST, CRUMPET, GRILL, REHEAT, WARM), place the food directly on the wire rack or on the included pizza pan, grilling rack and/or baking pan. Ensure the food is centered in the oven for the most even cooking.
  - a) Close the oven door.
  - b) Press the START/CANCEL button. The button backlight will illuminate red, the oven alert will sound, and the LCD screen will illuminate orange.
  - c) The timer will be displayed and begin to count down. The cooking temperature and time can be adjusted during the cooking cycle.

## OPERATING YOUR BREVILLE PRODUCT

6. For settings that feature a preheat cycle (BAKE, ROAST, PIZZA, COOKIES, SLOW COOK), press the START/ CANCEL button before placing food in the oven. The button backlight will illuminate red, the oven alert will sound and the LCD screen will indicate a blinking 'PREHEATING' while the oven is heating up.
  - a) When the oven is ready for use, the blinking 'PREHEATING' will go out, the oven alert will sound and the timer will start counting down. Place the food in the oven, either directly on the wire rack or on the included pizza pan, grilling rack and/or baking pan. Ensure the food is centered in the oven for the most even cooking.
  - b) Close the oven door.
  - c) The timer will continue to count down. The cooking temperature and time can be adjusted during the cooking cycle.
7. At the end of the cooking cycle, the oven alert will sound, the START/ CANCEL button backlight will go out and the LCD screen will illuminate blue.

### NOTE

The cooking cycle can be stopped at any time by pressing the START/ CANCEL button. This will cancel the cycle and the button backlight will go out.

## MAGNETIC AUTO-EJECT RACK

When the wire rack is inserted into the middle rack position, it will automatically eject halfway out of the oven when the door is opened so you can easily remove your toasted items.

Always open the door slowly when the wire rack is in this position to prevent the rack from ejecting too quickly.

## GRILL FUNCTION

The GRILL function is ideal for open-faced sandwiches, small cuts of meat, poultry and fish, sausages and vegetables. Grilling can also be used to brown the tops of casseroles and gratins.

1. Insert the wire rack, with the spokes facing upward, into the top rack height position.
2. Insert the included grilling rack into the baking pan. Place food on the assembled grilling rack or in an oven-proof dish, then place on the center of the wire rack so air flows around the sides of the food.
3. Close the oven door.
4. Turn the FUNCTION dial until the indicator on the LCD screen reaches the GRILL function. The top figure on the LCD screen indicates the preset grill setting of 'HI', while the bottom figure indicates the preset time of ':10 MINS'.



## OPERATING YOUR BREVILLE PRODUCT

5. The grill setting and time can be adjusted before or during the grilling cycle.
  - a) The grill setting is displayed as the top figure on the LCD screen. Turn the TEMPERATURE dial to adjust grilling to one of three pre-set temperatures: LO, MED or HI.
  - b) The grilling time is displayed as the bottom figure on the LCD screen. Turn the TIME dial to adjust the time up to 20 minutes.
6. Press the START/CANCEL button to activate the GRILL function. The button backlight will illuminate red, the oven alert will sound and the LCD screen will illuminate orange.
7. The timer will be displayed and automatically begin to count down. The temperature and time can be adjusted during the grilling cycle by turning the corresponding TEMPERATURE and TIME dial. The cycle can be stopped at any time by pressing the START/CANCEL button.
8. At the end of the GRILL cycle, the oven alert will sound. The START/CANCEL button backlight will go out and the LCD screen will illuminate blue.

## TOAST FUNCTION

The TOAST function browns and crisps the outside of your bread while keeping the inside soft and moist. This function is also ideal for English muffins and frozen waffles.

1. Insert the wire rack, with the spokes facing upward, into the middle rack height position.
2. If toasting 1-3 slices, center the slices on the wire rack. If toasting 4-6 slices, evenly space them with 2-3 slices at the front of the wire rack and 2-3 slices at the back of the rack.
3. Close the oven door.
4. Turn the FUNCTION dial until the indicator on the LCD screen reaches the TOAST function. The top figure on the LCD screen indicates the preset darkness setting '4', while the bottom figure indicates the preset number of slices '4'.

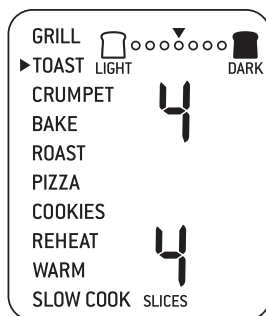

5. The darkness setting and number of slices can be adjusted before or during the toasting cycle.
  - a) The darkness setting is indicated by the row of circles at the top of the LCD screen. Turn the TEMPERATURE dial to the left to reduce the darkness setting, or to the right to increase it. The triangle above the circles will move according to the selected setting.

## OPERATING YOUR BREVILLE PRODUCT

As general guide:

DESIRED TOAST COLOUR	SETTING
Light	1 or 2
Medium	3, 4 or 5
Dark	6 or 7

- b) The number of slices is displayed as the bottom figure on the LCD screen. Turn the TIME dial to the left to reduce the number of slices, or to the right to increase it. The number of slices ranges from '1' to '6'.
6. Press the START/CANCEL button to start the TOAST function. The button backlight will illuminate red, the oven alert will sound, and the LCD screen will illuminate orange.
7. The timer will be displayed and automatically begin to count down. The time can be adjusted during the toasting cycle by turning the TIME dial. The cycle can be stopped at any time by pressing the START/CANCEL button.

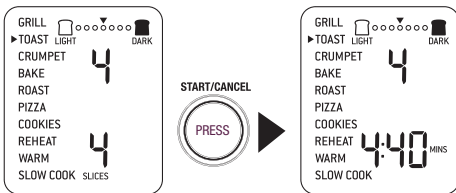

8. At the end of the TOAST cycle, the oven alert will sound. The START/CANCEL button backlight will go out and the LCD screen will illuminate blue.

## CRUMPET FUNCTION

The CRUMPET function crisps the top of your crumpet while only lightly toasting the base. This function is also ideal for toasting bagels or thick sliced specialty breads which require one side to be toasted more than the other.

1. Insert the wire rack, with the spokes facing upward, into the middle rack height position.
2. If toasting 1-3 crumpets, center on the wire rack. If toasting 4-6 crumpets, evenly space them with 2-3 crumpets at the front of the wire rack and 2-3 crumpets at the back of the rack.

### NOTE

**The top of the crumpet must always face upwards towards the top heating elements. This allows the top to get crisp while the base is only lightly toasted.**

3. Close the oven door.
4. Turn the FUNCTION dial until the indicator on the LCD screen reaches the CRUMPET function. The top figure on the LCD screen indicates the preset darkness setting '4', while the bottom figure indicates the preset number of crumpets '4'.

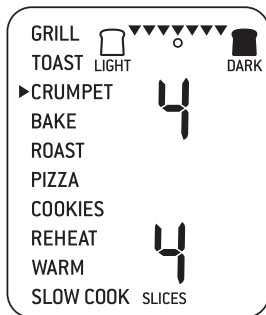

## OPERATING YOUR BREVILLE PRODUCT

5. The darkness setting and number of crumpets can be adjusted before or during the toasting cycle.
  - a) The darkness setting is indicated by the row of triangles at the top of the LCD screen. Turn the TEMPERATURE dial to the left to reduce the darkness setting, or to the right to increase it. The circle below the triangles will move according to the selected setting.
7. The timer will be displayed and automatically begin to count down. The time can be adjusted during the crumpet cycle by turning the TIME dial. The cycle can be stopped at any time by pressing the START/CANCEL button.

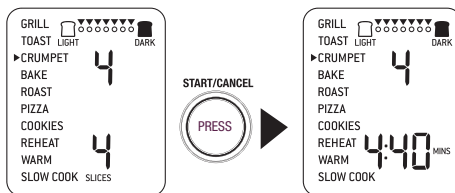

### As general guide:

DESIRED CRUMPET COLOUR	SETTING
Light	1 or 2
Medium	3, 4 or 5
Dark	6 or 7

- b) The number of crumpets is displayed as the bottom figure on the LCD screen. Turn the TIME dial to the left to reduce the number of crumpets, or to the right to increase it. The number of crumpets ranges from '1' to '6'.
6. Press the START/CANCEL button to start the CRUMPET function. The button backlight will illuminate red, the oven alert will sound, and the LCD screen will illuminate orange.
8. At the end of the CRUMPET cycle, the oven alert will sound. The START/CANCEL button backlight will go out and the LCD screen will illuminate blue.

### NOTE

If you like your crumpets equally crisp on both the top and bottom, we recommend using the TOAST function.

### BAKE FUNCTION

The BAKE function cooks food evenly throughout. This function is ideal for baking cakes, muffins, brownies and pastries. The BAKE function is also ideal for cooking pre-packaged frozen meals such as lasagna and pot pies.

1. Insert the wire rack, with the spokes facing upward, into the bottom rack height position. Note that some baked goods, such as brownies or pastries, may be more suited to the middle rack height position.
2. Close the oven door.
3. Turn the FUNCTION dial until the indicator on the LCD screen reaches the BAKE function. The top figure on the LCD screen indicates the preset BAKE temperature of 160°C, while the bottom figure indicates the preset time of ':30 MINS'. The preset CONVECTION setting will also be displayed.
4. The baking temperature and time can be adjusted before or during the baking cycle.
  - a) The baking temperature is displayed as the top figure on the LCD screen. Turn the TEMPERATURE dial to adjust the baking temperature from 50°C/120°F to a maximum of 230°C/450°F.
  - b) The baking time is displayed as the bottom figure on the LCD screen. Turn the TIME dial to select up to 2 hours for temperatures above 150°C/300°F and up to 10 hours for temperatures below 150°C/300°F.
5. Press the START/CANCEL button to activate the BAKE function. The button backlight will illuminate red, the oven alert will sound and the LCD screen will illuminate orange. The LCD screen will indicate a blinking 'PREHEATING'.
6. Once the oven has reached the set temperature, the temperature alert will sound.
7. Place food, positioned on the included baking pan or other oven-proof dish, on the center of the wire rack so air will flow around all sides of the food.





8. After the PREHEATING alert has sounded, the timer will automatically begin to count down. The temperature and time can be adjusted during the baking cycle by turning the corresponding TEMPERATURE and TIME dial. The cycle can be stopped at any time by pressing the START/CANCEL button.

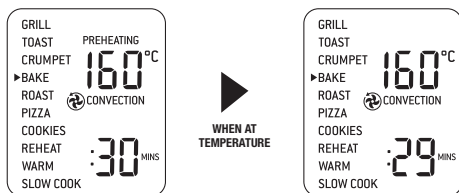
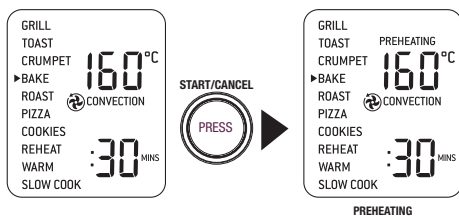

9. At the end of the BAKE cycle, the oven alert will sound. The START/CANCEL button backlight will go out and the LCD screen will illuminate blue.

## ROAST FUNCTION

The ROAST function is ideal for cooking a variety of meats and poultry. Food will be tender and juicy on the inside and roasted to perfection on the outside.

1. Insert the wire rack, with the spokes facing upward, into the bottom rack height position.
2. Close the oven door.
3. Turn the FUNCTION dial until the indicator on the LCD screen reaches the ROAST function. The top figure on the LCD screen indicates the preset ROAST temperature of 175°C, while the bottom figure indicates the preset time of '1:00HRS'. The preset CONVECTION setting will also be displayed.



4. The roasting temperature and time can be adjusted before or during the roasting cycle.
  - a) The roasting temperature is displayed as the top figure on the LCD screen. Turn the TEMPERATURE dial to adjust the baking temperature from 50°C/120°F to a maximum of 230°C/450°F.
  - b) The roasting time is displayed as the bottom figure on the LCD screen. Turn the TIME dial to select up to 2 hours for temperatures above 150°C/300°F and up to 10 hours for temperatures below 150°C/300°F.

## OPERATING YOUR BREVILLE PRODUCT

5. Press the START/CANCEL button to activate the ROAST function. The button backlight will illuminate red, the oven alert will sound and the LCD screen will illuminate orange. The LCD screen will indicate a blinking 'PREHEATING'.
6. Once the oven has reached the set temperature, the temperature alert will sound.
7. Place food, positioned on the included baking pan or other oven-proof dish, on the center of the wire rack so air will flow around all sides of the food.
8. After the PREHEATING alert has sounded, the timer will automatically begin to count down. The temperature and time can be adjusted during the roasting cycle by turning the corresponding TEMPERATURE and TIME dial. The cycle can be stopped at any time by pressing the START/CANCEL button.

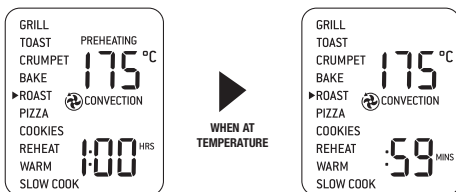
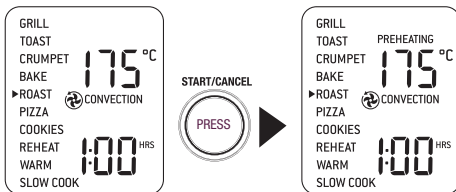

9. At the end of the ROAST cycle, the oven alert will sound. The START/CANCEL button backlight will go out and the LCD screen will illuminate blue.

## PIZZA FUNCTION

The PIZZA function melts and browns cheese and toppings, while crisping up the pizza crust.

1. Insert the wire rack, with the spokes facing upward, into the middle rack height position.
2. Close the oven door.
3. Turn the FUNCTION dial until the indicator on the LCD screen reaches the PIZZA function. The top figure on the LCD screen indicates the preset PIZZA temperature of '210°C', while the bottom figure indicates the preset time of ':20 MINS'. The preset CONVECTION and FROZEN settings will also be displayed.



4. The pizza temperature and time can be adjusted before or during the cycle.
  - a) The pizza temperature is displayed as the top figure on the LCD screen. Turn the TEMPERATURE dial to adjust the baking temperature from 50°C/120°F to a maximum of 230°C/450°F.
  - b) The pizza time is displayed as the bottom figure on the LCD screen. Turn the TIME dial to adjust the time up to 2 hours.

## OPERATING YOUR BREVILLE PRODUCT

5. Press the START/CANCEL button to activate the PIZZA function. The button backlight will illuminate red, the oven alert will sound and the LCD screen will illuminate orange. The LCD screen will indicate a blinking 'PREHEATING'.
6. Once the oven has reached the set temperature, the temperature alert will sound.
7. Place food, positioned on the included pizza pan, on the center of the wire rack so air will flow around all sides of the food.
8. After the PREHEATING alert has sounded, the timer will automatically begin to count down. The temperature and time can be adjusted during the cycle by turning the corresponding TEMPERATURE and TIME dial. The cycle can be stopped at any time by pressing the START/CANCEL button.

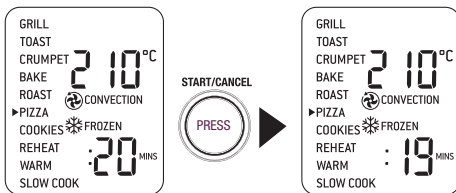

9. At the end of the PIZZA cycle, the oven alert will sound. The START/CANCEL button backlight will go out and the LCD screen will illuminate blue.

### A note on pizza stones

When using a pizza stone, it is necessary to first heat the stone (without a pizza) for optimum results.

1. Insert the wire rack, with the spokes facing upward, into the middle rack height position.
2. Place pizza stone on the center of the wire rack so air will flow around all sides of the stone.
3. Close the door.
4. Turn the TIME dial to the left to reduce the time to '15 MINS'. The time is displayed as the bottom figure on the LCD screen. The preset CONVECTION and FROZEN settings will also be displayed.
5. Press the START/CANCEL button to activate the PIZZA function. The button backlight will illuminate red, the oven alert will sound and the LCD screen will illuminate orange. The LCD screen will indicate a blinking 'PREHEATING'.
6. Once the oven has reached the set temperature, the temperature alert will sound.
7. After the PREHEATING alert has sounded, the timer will automatically begin to count down.
8. At the end of the cycle, the oven alert will sound. The START/CANCEL button backlight will go out and the LCD screen will illuminate blue.
9. Open the oven door and carefully place frozen pizza on the heated pizza stone. When cooking fresh pizza, carefully remove the entire wire rack with pizza stone using insulated oven mitts. Place on the counter and transfer the fresh pizza dough onto the heated stone before placing back into the oven.
10. Select desired PIZZA setting and press the START/CANCEL button to re-start the PIZZA cycle.

### COOKIES FUNCTION

The COOKIES function is ideal for baking homemade or commercially prepared cookies and other baked treats.

Ready-to-bake crescent rolls, cinnamon scrolls, biscuits and strudels are ideally baked using this function.

1. Insert the wire rack, with the spokes facing upward, into the middle rack height position.
2. Close the oven door.
3. Turn the FUNCTION dial until the indicator on the LCD screen reaches the COOKIES function. The top figure on the LCD screen indicates the preset temperature of 175°C, while the bottom figure indicates the preset time of '11 MINS'. The preset CONVECTION setting will also be displayed.



4. The baking temperature and time can be adjusted before or during the cookie cycle.
  - a) The baking temperature is displayed as the top figure on the LCD screen. Turn the TEMPERATURE dial to adjust the baking temperature from 50°C/120°F to a maximum of 230°C/450°F.
  - b) The baking time is displayed as the bottom figure on the LCD screen. Turn the TIME dial to adjust the time up to 1 hour.
5. Press the START/CANCEL button to activate the COOKIES function. The button backlight will illuminate red, the oven alert will sound and the LCD screen will illuminate orange. The LCD screen will indicate a blinking 'PREHEATING'.
6. Once the oven has reached the set temperature, the temperature alert will sound.
7. Place food, positioned on the included baking pan, pizza pan or other oven-proof dish, on the center of the wire rack so air will flow around all sides of the food.
8. After the PREHEATING alert has sounded, the timer will automatically begin to count down. The temperature and time can be adjusted during the cycle by turning the corresponding TEMPERATURE and TIME dial. The cycle can be stopped at any time by pressing the START/CANCEL button.
9. At the end of the COOKIES cycle, the oven alert will sound. The START/CANCEL button backlight will go out and the LCD screen will illuminate blue.

### REHEAT FUNCTION

The REHEAT function is ideal for reheating leftovers without browning.

1. Insert the wire rack, with the spokes facing upward, into the bottom rack height position.
2. Place food, positioned on the included baking pan, pizza pan or other oven-proof dish, on the center of the wire rack so air will flow around all sides of the food.
3. Close the oven door.
4. Turn the FUNCTION dial until the indicator on the LCD screen reaches the REHEAT function. The top figure on the LCD screen indicates the preset temperature of '165°C', while the bottom figure indicates the preset time of ':15 MINS'. The preset CONVECTION setting will also be displayed.
5. The reheating temperature and time can be adjusted before or during the reheating cycle.
  - a) The temperature is displayed as the top figure on the LCD screen. Turn the TEMPERATURE dial to adjust the temperature from 50°C/120°F to a maximum of 230°C/450°F.
  - b) The time is displayed as the bottom figure on the LCD screen. Turn the TIME dial to adjust the time up to 2 hours.
6. Press the START/CANCEL button to activate the REHEAT function. The button backlight will illuminate red, the oven alert will sound and the LCD screen will illuminate orange.
7. The timer will be displayed and begin to count down. The temperature and time can be adjusted during the reheating cycle by turning the corresponding TEMPERATURE and TIME dial. The cycle can be stopped at any time by pressing the START/CANCEL button.
8. At the end of the REHEAT cycle, the oven alert will sound. The START/CANCEL button backlight will go out and the LCD screen will illuminate blue.



### WARM FUNCTION

The WARM function maintains hot foods at the recommended temperature to prevent bacterial growth (70°C/160°F or above).

1. Insert the wire rack, with the spokes facing upward, into the bottom rack height position.
2. Place food, positioned on the included baking pan, pizza pan or other oven-proof dish, on the center of the wire rack so air will flow around all sides of the food.
3. Close the oven door.
4. Turn the FUNCTION dial until the indicator on the LCD screen reaches the WARM function. The top figure on the LCD screen indicates the preset temperature of '70°C', while the bottom figure indicates the preset time of '1:00 HRS'. The preset KEEP WARM symbol will also be displayed.
5. The warming temperature and time can be adjusted before or during the warming cycle.
  - a) The temperature is displayed as the top figure on the LCD screen. Turn the TEMPERATURE dial to adjust the temperature from 50°C/120°F to a maximum of 230°C/450°F.
  - b) The time is displayed as the bottom figure on the LCD screen. Turn the TIME dial to adjust the time up to 2 hours.
6. Press the START/CANCEL button to activate the WARM function. The button backlight will illuminate red, the oven alert will sound and the LCD screen will illuminate orange.
7. The timer will be displayed and automatically begin to count down. The temperature and time can be adjusted during the warming cycle by turning the corresponding TEMPERATURE and TIME dial. The cycle can be stopped at any time by pressing the START/CANCEL button.
8. At the end of the WARM cycle, the oven alert will sound. The START/CANCEL button backlight will go out and the LCD screen will illuminate blue.



### SLOW COOK FUNCTION

The SLOW COOK function has cooking profiles designed for long cook times at low temperatures.

1. Insert the wire rack, with the spokes facing upward, into the bottom rack height position.
2. Close the oven door.
3. Turn the FUNCTION dial until the indicator on the LCD screen reaches the SLOW COOK function. The top figure on the LCD screen indicates the preset SLOW COOK setting of 'HI', while the bottom figure indicates the preset time of '4:00HRS'. The preset CONVECTION setting will also be displayed.



4. The slow cook setting and time can be adjusted:
  - a) The slow cook setting is displayed as the top figure on the LCD screen. Turn the TEMPERATURE dial to adjust slow cooking to one of two preset temperatures: 'LO' or 'HI'.
  - b) The time is displayed as the bottom figure on the LCD screen. Turn the TIME dial to adjust the time between 8 and 10 hours for 'LO' and between 4 and 6 hours for 'HI'.

5. Press the START/CANCEL button to activate the SLOW COOK function. The button backlight will illuminate red, the oven alert will sound and the LCD screen will illuminate orange. The LCD screen will indicate a blinking 'PREHEATING'.
6. Once the oven has reached the set temperature, the temperature alert will sound.
7. Place food, inside oven-proof cookware, on the center of the wire rack so air will flow around all sides of the food.
8. After the PREHEATING alert has sounded, the timer will automatically begin to count down. Time can be adjusted during the slow cook cycle by turning the corresponding TIME dial. The cycle can be stopped at any time by pressing the START/CANCEL button.
9. At the end of the SLOW COOK cycle, the oven will automatically switch to the WARM function. The LCD screen will display 'KEEP WARM' and the maximum keep warm time of '2:00 HRS' will automatically count down. The keep warm cycle can be stopped at any time by pressing the START/CANCEL button.

### NOTE

**Do not pull the wire rack further than halfway out when inserting or removing the cookware from the oven.**

### TIPS FOR SLOW COOKING

1. Ensure cookware is ovenproof and does not exceed 6 kg when empty.
2. Fill cookware to minimum  $\frac{1}{2}$  and maximum  $\frac{3}{4}$  full to avoid over or under-cooking. To prevent spillover, do not fill cookware more than  $\frac{3}{4}$  full.
3. Always slow cook with the lid on to prevent food from drying out. Cover cookware with a layer of aluminum foil before covering with lid to keep even more moisture in.
4. Follow cooking settings and times prescribed in traditional slow cooker recipes. One hour on 'HI' is equivalent to approximately one-and-a-half to two hours on 'LO'.
5. Cold food will take longer to cook than food that has been pre-seared or heated so adjust cooking times as appropriate. Do not slow cook frozen foods.

### USING THE WARMING TRAY

The top of the oven is very hot during and after operation. As a result, storing items on top of the oven is not recommended.

The only exception is the optional Breville Bamboo Cutting Board and Serving Tray that fits in the ribbed section on top of the oven. Visit [www.breville.com](http://www.breville.com) for more information.

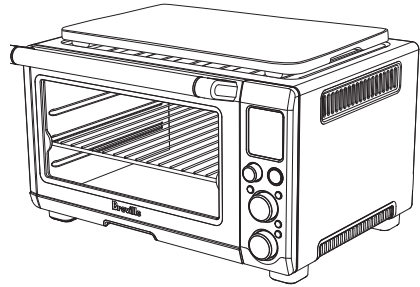



## REPLACING THE OVEN LIGHT

### **WARNING**

*Always unplug oven and let cool before replacing bulb. Only use a 25-Watt, 220-240V, G9 type oven bulb.*

1. Remove the wire rack from the oven before replacing the light.
2. The light is positioned on the left-hand side of the oven cavity. Position your fingers on the outside of the light housing and gently pull the glass cover away from the oven wall to remove it. If you are unable to pull the cover off, slide a spoon into the left side of the light housing and gently lever the glass cover off. Always hold the glass cover with the other hand to prevent the cover from falling and breaking.

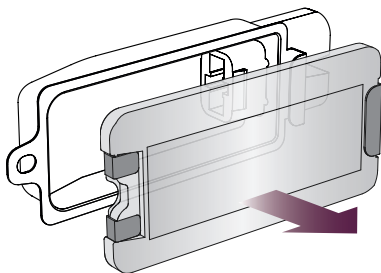

3. Remove the used bulb by pulling it directly out of its holder.

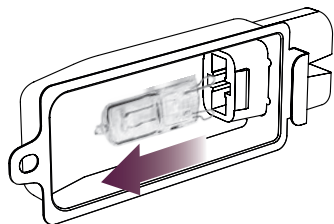

4. Use a soft cloth to insert the new bulb. Do not directly touch the surface of the bulb with your fingers as oil from your skin can damage the bulb.

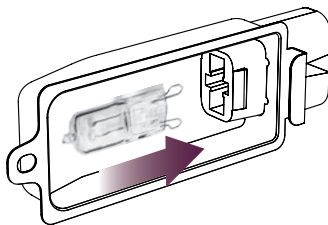

5. To reattach the glass cover, align the metal hook with the left side of the light housing. Slide the opposite end of the glass cover into the metal bracket on the right side of the housing, then push the metal hook into the left side of the housing until it snaps securely into position.

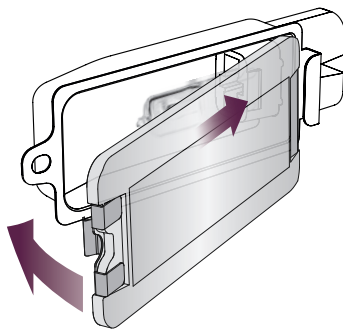

Before cleaning, ensure the oven is turned off by pressing the START/CANCEL button on the control panel. The oven is off when the button backlight is no longer illuminated.

Remove the power plug from the power outlet. Allow the oven and all accessories to cool completely before disassembling and cleaning.

### Cleaning the outer body and door

1. Wipe the outer body with a soft, damp sponge. A non-abrasive liquid cleanser or mild spray solution may be used to avoid build-up of stains. Apply the cleanser to the sponge, not the oven surface, before cleaning.
2. To clean the glass door, use a glass cleaner or mild detergent and a soft, damp sponge or soft plastic scouring pad. Do not use an abrasive cleanser or metal scouring pad as these will scratch the oven surface.
3. Wipe the LCD screen with a soft damp cloth. Apply cleanser to the cloth and not the LCD surface. Cleaning with dry cloth or abrasive cleaners may scratch the surface.
4. Let all surfaces dry thoroughly prior to inserting the power plug into a power outlet and turning the oven on.



### **WARNING**

*Do not immerse the body, power cord or power plug in water or any other liquid as this may cause electrocution.*

### Cleaning the interior

1. The walls on the inside of the oven feature a non-stick coating for easy cleaning. To clean any spattering that may occur while cooking, wipe the walls with a soft, damp sponge. A non-abrasive liquid cleanser or mild spray solution may be used to avoid build-up of stains. Apply the cleanser to the sponge, not the oven surface, before cleaning. Avoid touching the quartz heating elements.



### **WARNING**

*Use extreme caution when cleaning the quartz heating elements. Allow the oven to cool completely, then gently rub a soft, damp sponge or cloth along the length of the heating element. Do not use any type of cleanser or cleaning agent. Let all surfaces dry thoroughly prior to inserting the power plug into a power outlet and turning the oven on.*

2. Let all surfaces dry thoroughly prior to inserting the power plug into a power outlet and turning the oven on.

### Cleaning the crumb tray

1. After each use, slide out the crumb tray and discard crumbs. Wipe the tray with a soft, damp sponge. A non-abrasive liquid cleanser may be used to avoid build-up of stains. Apply the cleanser to the sponge, not the tray, before cleaning. Dry thoroughly.
2. To remove baked-on grease, soak the tray in warm soapy water then wash with a soft sponge or soft plastic scouring pad. Rinse and dry thoroughly.
3. Always ensure to re-insert the crumb tray into the oven after cleaning and prior to inserting the power plug into a power outlet and turning the oven on.

### Cleaning the wire rack, grilling rack, baking pan and pizza pan

1. Wash all accessories in warm soapy water with a soft sponge or soft plastic scouring pad. Rinse and dry thoroughly. Do not use abrasive cleansers, metal scouring pads or metal utensils to clean any of the accessories as they may damage the surfaces.
2. To extend the life of your accessories, we do not recommend that these be placed in the dishwasher.

### Storage

1. Ensure the oven is turned off by pressing the START/CANCEL button on the control panel. The oven is off when the button backlight is no longer illuminated.
2. Remove the power plug from the power outlet. Allow the oven and all accessories to cool completely before disassembling and cleaning.
3. Ensure the oven and all accessories are clean and dry.
4. Ensure the crumb tray is inserted into the oven; the grilling rack is inserted into the baking pan and resting on the wire rack in the middle rack height position.
5. Ensure the door is closed.
6. Store the appliance in an upright position standing level on its support legs. Do not store anything on top. The only exception is the optional Breville Bamboo Cutting Board and Serving Tray.

## TROUBLESHOOTING

POSSIBLE PROBLEM	EASY SOLUTION
<b>Oven will not switch "ON"</b>	<ul style="list-style-type: none"> <li>• Check that the power plug is securely inserted into the outlet.</li> <li>• Insert the power plug into an independent outlet.</li> <li>• Insert the power plug into a different outlet.</li> <li>• Reset the circuit breaker if necessary.</li> </ul>
<b>I would like to have the oven LCD default settings back</b>	<ul style="list-style-type: none"> <li>• The oven will remember the last setting used for each function unless you remove the plug from the power outlet.</li> <li>• To restore the oven's default settings for each function, remove the plug from the power outlet. Wait 5 seconds, then plug back in.</li> </ul>
<b>The LCD display light has gone out</b>	<ul style="list-style-type: none"> <li>• The oven goes into standby mode if not used for 10 minutes. When in standby mode, the LCD screen will cease to illuminate, however all function options will still be visible.</li> <li>• To re-activate the oven out of standby mode, press the START/CANCEL button on the control panel, or turn any dial. The LCD screen will re-illuminate.</li> </ul>
<b>The pizza does not cook evenly</b>	<ul style="list-style-type: none"> <li>• Some large pizzas may brown unevenly in compact ovens. Open the oven door half way through the cooking time and turn the pizza 90 degrees for more even darkness.</li> </ul>
<b>The Magnetic Auto-Rack Eject comes out too far when I open the door</b>	<ul style="list-style-type: none"> <li>• Always open the door slowly and in a controlled manner when the wire rack is inserted into the middle rack height position to prevent the wire rack from ejecting too quickly.</li> </ul>
<b>I cannot select the FROZEN FOODS button</b>	<ul style="list-style-type: none"> <li>• The FROZEN FOODS button is only selectable during the TOAST, CRUMPET, PIZZA and COOKIES functions.</li> </ul>
<b>Steam is coming out from the top of the oven door</b>	<ul style="list-style-type: none"> <li>• This is normal. The door is vented to release steam created from high-moisture content foods such as frozen breads.</li> </ul>
<b>The heating elements appear to be pulsing</b>	<ul style="list-style-type: none"> <li>• Element IQ® accurately controls the heat inside the oven by pulsing the power in the heating elements in short bursts. This is normal.</li> </ul>
<b>Water is dripping onto the bench top from under door</b>	<ul style="list-style-type: none"> <li>• This is normal. The condensation created from high moisture content foods such as frozen breads will run down the inside of the door and can drip onto the bench top.</li> </ul>
<b>The temperature reading on the LCD screen doesn't match the temperature measured inside the oven.</b>	<ul style="list-style-type: none"> <li>• To ensure the measurements are standardized, the oven temperatures have been calibrated in the TOAST position (center of the middle rack with no tray in place). Re-check the temperature in this position, ensuring not to open the oven door for 10 minutes as heat will escape each time the door is opened. Note that the 'preheat' alert sounds at 75% of the target temperature.</li> </ul>

## TROUBLESHOOTING

POSSIBLE PROBLEM	EASY SOLUTION
<p><b>The 'preheat' alert sounds at a lower temperature than what is displayed on the LCD screen.</b></p>	<ul style="list-style-type: none"> <li>• The 'preheat' alert sounds at 75% of the target temperature. This provides the fastest, combined preheating and cooking time.</li> <li>• This is because when the 'preheating' alert sounds, signaling the user to open the oven door and insert food, there is dramatic temperature loss inside the oven. If the alert sounded at 100% of the target temperature, opening the door would mean a lot of this waiting time is "wasted". We have calculated that by sounding the alert at 75% of the target temperature, followed by the oven door being opened to place food inside the oven, that we still recover to the target temperature up to 2 minutes faster. This is why the temperature on the LCD screen does not match the target temperature at the 'preheat' alert. In total, it takes the oven approximately 8-10 minutes from start-up, including opening the oven door when the 'preheat' alert sounds, to reach the target temperature. To ensure the fastest heat up time, the Breville oven uses the maximum allowable power from the outlet (1500W for baking, 2400W for toasting).</li> </ul>
<p><b>The LCD screen displays 'E01'</b></p>	<ul style="list-style-type: none"> <li>• The LCD screen will display 'E01' when there is a non-resettable issue with the appliance. Should this occur, immediately remove the power cord from the power outlet and call Breville Customer Service.</li> </ul>
<p><b>The LCD screen displays 'E02'</b></p>	<ul style="list-style-type: none"> <li>• The LCD screen will display 'E02' when there is a non-resettable issue with the appliance. Should this occur, immediately remove the power cord from the power outlet and call Breville Customer Service.</li> </ul>
<p><b>The LCD screen displays 'E03'</b></p>	<ul style="list-style-type: none"> <li>• The LCD screen will display 'E03' if the oven temperature is above the set maximum limit. Remove the plug from the power outlet, allow the oven to cool for 15 minutes, then plug back in.</li> <li>• Call Breville Customer Service if the 'E03' message continues.</li> </ul>
<p><b>The LCD screen displays 'E04'</b></p>	<ul style="list-style-type: none"> <li>• The LCD screen will display 'E04' if the room temperature is below the set minimum. Unplug the oven and relocate to a warmer area.</li> </ul>
<p><b>The LCD screen displays 'E05'</b></p>	<ul style="list-style-type: none"> <li>• The LCD screen will display 'E05' when there is a non-resettable issue with the appliance. Should this occur, immediately remove the power cord from the power outlet and call Breville Customer Service.</li> </ul>

# RECIPES

## PIZZA DOUGH

Makes two 30cm pizzas

### INGREDIENTS

- ¾ cup + 2 tablespoons warm water
- 1 teaspoon sugar
- 2 teaspoons instant yeast
- 500g unbleached plain flour
- 1 teaspoon salt

### METHOD

1. Combine the water with sugar and yeast until well dissolved. Allow to stand for 3 minutes.
2. Mix together the flour and salt. Pour the yeast mixture into the flour and mix to form a ball.
3. Transfer the dough to a work surface and knead for 7 to 10 minutes, or until it is smooth and elastic.
4. Grease the inside of a medium bowl with olive oil. Place the dough in the bowl, turning it to coat all sides. Cover the bowl with plastic wrap and place it in a warm, draft-free area. Allow the dough to rise until doubled in size, about 30 minutes.
5. Punch down the dough and divide it in half. Shape each half into a ball. Spray each ball lightly with cooking spray and cover loosely with plastic wrap. Let rest for 10 minutes.
6. Stretch the dough to fit a non-stick pizza pan and top with your favorite toppings.
7. Position the wire rack in the middle rack height position and turn the FUNCTION dial until the indicator on the LCD screen points to the PIZZA function. De-select the FROZEN and CONVECTION settings and leave the default temperature and time settings. Press the START/CANCEL button to activate.

8. When preheating has completed, place the pizza pan on the wire rack and cook until the cheese is melted and the crust is golden brown.

### TIP

For a crispier crust, cook for an additional minute or two.

## PIZZA RECIPE SUGGESTIONS

### MARGHERITA

½ cup tomato sauce, fresh mozzarella cheese, fresh basil leaves, drizzle with olive oil.

### PICANTE

½ cup tomato sauce, smoked mozzarella cheese, thinly sliced hot salami, sliced green olives, drizzle with chili oil.

### TRE-FUNGHI

½ cup tomato sauce, mozzarella cheese, button, oyster and Swiss brown mushrooms sautéed with chopped fresh rosemary and thyme, sprinkle with grated Parmesan.

### DESSERT PIZZAS

Brush melted butter on the pizza dough and sprinkle with 1 tablespoon sugar and ½ teaspoon cinnamon. Bake as directed then top with one of the following combinations:

### BANANA CHOCOLATE

Sliced bananas, melted chocolate. If desired, serve with vanilla ice cream.

### CARAMELIZED PEAR AND WALNUT

½ cup mascarpone cheese mixed with 2 tablespoons honey, thinly sliced pears sautéed in butter and sugar, toasted walnuts.

## ROASTED BUTTERNUT PUMPKIN SOUP

Serves 6–8

### INGREDIENTS

- 1 butternut pumpkin, peeled and cut into 2cm cubes
- 1 small onion, chopped
- 2 tablespoons olive oil
- 1 apple, peeled and cut into 1-inch cubes
- 4 sprigs fresh thyme, leaves pulled off
- 1 leek, white and light green part only
- 40g unsalted butter
- 2 teaspoons curry powder
- 1.25 litres chicken stock
- ½ cup sour cream

### METHOD

1. In a large bowl, combine pumpkin, onion, olive oil, apple and thyme leaves. Season with salt and pepper.
2. Place the ingredients on a baking pan lined with foil or baking paper.
3. Position the wire rack in the bottom rack height position. Turn the FUNCTION dial until the indicator on the LCD screen points to the ROAST function. Set the temperature to 200°C with convection on and set the timer to 30 minutes. Press START/CANCEL to activate.
4. While the pumpkin mixture roasts, slice the leek in half lengthwise. Rinse it under cold running water to clean off any dirt that may be trapped in between the layers. Slice into 1cm slices.
5. Melt the butter in a medium pot over medium heat. When the butter starts to foam, add the leek and cook until softened, about 7 minutes. Add the curry powder, season with salt and pepper and continue to cook for 1 minute.
6. Add the roasted squash mixture to the pot and stir to coat with the spices.
7. Deglaze the pot with a cup of the chicken stock, scraping the bottom of the pot to release any stuck-on bits. Add the remaining chicken stock and bring to a boil.
8. Reduce to a simmer and cook, covered, for 20 minutes. Cool to room temperature then puree in batches in a blender or food processor.
9. Return the pureed soup to the pot and heat to serving temperature. Garnish with dollops of sour cream.



## HERBED LEG OF LAMB

Serves 6–8

### INGREDIENTS

- 4 cloves garlic, chopped
- 2 teaspoons sea salt
- 1 teaspoon black pepper
- 3 tablespoons Dijon mustard
- ¼ cup fresh rosemary leaves, loosely packed
- 3 tablespoons fresh oregano leaves
- 3 tablespoons Italian parsley leaves
- 2 tablespoons honey
- ¼ cup olive oil
- 2kg leg of lamb

### METHOD

1. In a blender or food processor, pulse together the garlic, salt, pepper, Dijon mustard, rosemary, oregano, parsley and honey. With the machine running, drizzle in the olive oil. Place the lamb on a glass dish and pour the marinade over it, making sure to completely coat the lamb. Cover with plastic wrap and marinate in the refrigerator at least 4 hours or overnight.
2. Remove the lamb from the dish and place it on the grilling rack inserted into the baking pan.
3. Position the wire rack in the bottom rack height position and turn the FUNCTION dial until the indicator on the LCD screen points to the ROAST function. Set the temperature to 220 °C with convection on and set the timer for 20 minutes. Press START/CANCEL button to activate.
4. When preheating has completed, place the baking pan on the wire rack and cook for 20 minutes. Reduce the temperature to 160 °C and roast for 1 hour and 20 minutes, or until a meat thermometer inserted into the thickest part of the meat (not near the bone) registers your preferred doneness.
5. Remove the roast and tent with foil. Allow to rest for 20 minutes before carving.

### NOTE

To reach the desired doneness of a roast, it is best to remove the roast when the internal temperature is 10 °F (5 °C) below the desired temperature reading. The internal temperature of the roast will continue to rise during resting. Resting prior to carving also allows the roast to retain its juices.

## TANDOORI CHICKEN

**Serves 6**

### INGREDIENTS

- 1 cup Greek yogurt
- Juice of 1 lemon
- 1 tablespoon grated fresh ginger
- 1 tablespoon minced garlic
- 2 teaspoons ground coriander
- 2 teaspoons ground cumin
- 2 teaspoons garam masala
- 1 ½ teaspoons sea salt
- ½ teaspoon black pepper
- 1 teaspoon paprika
- ½ teaspoon cayenne pepper
- 2 tablespoons honey
- 12 bone-in skinless chicken thighs

### METHOD

1. In a medium sized bowl, combine all ingredients except for the chicken.
2. Cut three diagonal slits on each chicken thigh, cutting nearly to the bone.
3. Pour the marinade into a re-sealable plastic bag; add the chicken and turn to coat. Refrigerate at least 2 hours or overnight.
4. Remove the chicken from the bag, wiping off any excess marinade. Place the chicken on the grilling rack inserted into the baking pan.
5. Position the wire rack in the bottom rack height position. Turn the FUNCTION dial until the indicator on the LCD screen points to the ROAST function. Set the temperature to 200°C with convection turned on and set the timer for 35 minutes. Press the START/CANCEL button to activate.
6. When preheating has completed, place the roasting pan on the wire rack and roast the chicken for 35 minutes or until a meat thermometer registers 75°C when inserted into the deepest part of the thigh.

## BEEF STEW

Serves 2

### INGREDIENTS

1kg chuck steak, cut into 3cm cubes  
 1 teaspoon kosher salt  
 1 teaspoon freshly ground black pepper  
 2 tablespoons olive oil  
 1 medium onion, chopped  
 1 carrot, chopped  
 2 stalks celery, chopped  
 2 cloves garlic, minced  
 1/3 cup plain flour  
 1/2 cup red wine  
 1/4 cup tomato paste

420g can diced tomatoes  
 1/2 cup water  
 1 bay leaf  
 2 sprigs thyme

### METHOD

1. Pat beef dry and season with salt and black pepper.
2. Heat oil in a flameproof large casserole dish over medium-high heat for 2 minutes. Brown meat in 2 batches, about 8 minutes per batch. Transfer to a platter.
3. Add onion, carrots, and celery and cook, stirring occasionally, until well browned, about 5 minutes. Add garlic and cook for 1 minute.
4. Sprinkle flour over vegetables and cook, stirring constantly, for 2 minutes.
5. Stir in wine and tomato paste and cook 2 minutes or until wine is mostly evaporated.
6. Add diced tomatoes, water, bay leaf, and thyme. Scrape any browned bits from the bottom and sides of the pot into the liquid.
7. Add beef and any juices from platter back to the casserole dish, stirring to combine. Season with salt and pepper as needed.
8. Position the wire rack in the bottom rack height position. Turn the FUNCTION dial until the indicator on the LCD screen points to the SLOW COOK function. Select 'HI' for 4 to 6 hours or 'LO' for 6 to 8 hours. Press the START/CANCEL button to activate.
9. When preheating has completed, place covered Dutch oven on the wire rack and cook until beef is tender and stew has thickened.

### NOTE

If you don't have a small Dutch oven you can also use a pot or skillet to start the recipe, then transfer everything to a 1 to 2-quart oven-safe dish for the slow cook step.

**SPICY BEEF AND BLACK BEAN CHILI****Serves 6–8****INGREDIENTS**

1 tablespoon olive oil  
2 medium onions, finely chopped  
1 medium carrot, finely chopped  
1 red capsicum, finely chopped  
6 cloves garlic, minced  
1 jalapeno chili, minced  
1kg minced beef  
1½ teaspoons sea salt, more as needed  
2 teaspoons chili powder  
2 tablespoons ground cumin  
1 tablespoon ground coriander  
1 teaspoon dried oregano  
2 x 400g can diced tomatoes  
2 x 400g cans black beans, drained and rinsed

**METHOD**

1. Heat oil in a large Dutch oven over medium-high heat until it shimmers. Add onions, carrot and capsicums; season with salt and saute until brown, about 6 minutes. Add garlic and chilies; saute 1 minute.
2. Add minced beef, salt, chili powder, cumin, coriander and oregano to pot. Saute until brown, breaking up clumps, about 5 minutes. Drain off excess fat, if desired.
3. Add remaining ingredients and stir to combine.
4. Position the wire rack in the bottom rack height position. Turn the FUNCTION dial until the indicator on the LCD screen points to the SLOW COOK function. Select 'HI' for 4 to 6 hours or 'LO' for 6 to 8 hours. Press the START/CANCEL button to activate.
5. When preheating has completed, place covered Dutch oven on the wire rack and cook until chili has thickened and flavors are well combined.

## TRIPLE CHOCOLATE CHIP COOKIES

Makes 3 dozen cookies

### INGREDIENTS

- 180g unsalted butter, softened
- 1/3 cup caster sugar
- 3/4 cup brown sugar
- 1 egg
- 1 teaspoon vanilla extract
- 60g bittersweet chocolate, melted
- 1 3/4 cups plain flour
- 3/4 teaspoon bi-carb soda
- 2 teaspoons cornflour
- 3/4 teaspoon salt
- 1 cup semi-sweet chocolate chips
- 1 cup milk chocolate chips

### METHOD

1. Cream together the butter and sugars with electric beaters until light and creamy. Beat in the egg.
2. Add vanilla and melted chocolate and stir until combined. Sift together the flour, baking soda, cornflour and salt.
3. Add the dry ingredients to the creamed butter mixture and mix until just combined. Gently stir in the chocolate chips.
4. Drop tablespoons of cookie dough 5cm apart, onto a nonstick baking pan.
5. Position the rack in the middle rack height position. Turn the FUNCTION dial until the indicator on the LCD screen points to the COOKIES function. Set the temperature to 175°C and the timer to 9 minutes. Press the START/CANCEL button to activate.
6. When preheating has completed, place the baking pan on the wire rack and bake until cookies are set and slightly dried around the edges.
7. Remove baking pan from oven and allow cookies to cool on the pan for 1 minute then transfer to a cooling rack.
8. Repeat with remaining dough.

### TIP

Use a medium sized ice cream scoop to portion the cookies evenly onto a baking tray lined with baking paper. Freeze the cookie dough balls until firm, and then store them in a re-sealable plastic bag. Remove desired number of cookie dough balls from plastic bag, place on the baking pan and bake using the default cookie setting with convection and frozen setting turned on.





